

Praise
to
transparency

ALVECO 
POLYCARBONATE

ALVECO s.r.l. WAS BORN FROM THE ENTHUSIASM OF RESPONDING TO THE NEEDS OF A VAST CLIENTELE, ATTENTIVE TO INNOVATIONS IN THE FIELD OF PLASTICS. SINCE WE ARRIVED ON THE MARKET IN THE SUMMER OF 2016, WE HAVE WORKED WITH COMMITMENT AND FLEXIBILITY TO MEET THE DEMANDS OF DIVERSIFIED MERCHANDISE SECTORS.

OUR PASSION FOR EXCELLENCE HAS LED US TO PRODUCE MODULAR SYSTEMS, COMPACT AND CELLULAR POLYCARBONATE SHEETS AND PROFILES OF THE HIGHEST QUALITY, WITH PARTICULAR ATTENTION TO THE CONSTRUCTION SECTOR. THE RANGE OF OUR PRODUCTS, WHICH YOU CAN DISCOVER IN THE FOLLOWING PAGES, IS MADE WITH CUTTING-EDGE TECHNOLOGIES AND WITH MAXIMUM RESPECT FOR THE ENVIRONMENT, DEMONSTRATING OUR COMMITMENT TO ECO-SUSTAINABILITY.

WE ARE CONVINCED THAT OUR ATTENTION TO QUALITY AND INNOVATION IS WHAT SETS US APART. WE HOPE TO BE ABLE TO COLLABORATE WITH YOU TO REALIZE EVEN MORE EXTRAORDINARY PROJECTS!

POLYCARBONATE: WHAT IS IT?

A THERMOPLASTIC POLYMER CHARACTERIZED BY TRANSPARENCY, STURDINESS, FLEXIBILITY, LIGHTNESS, IMPACT RESISTANCE, AND THERMAL AND ACOUSTIC INSULATION. IT IS USED IN A VARIETY OF SECTORS, PARTICULARLY IN THE CIVIL AND INDUSTRIAL BUILDING SECTORS.

POLYCARBONATE: HOW IS IT PRODUCED?

IT IS OBTAINED THROUGH A PLASTIC DEFORMATION PROCESS CALLED "EXTRUSION", WHICH ALLOWS THE PRODUCTION OF SHEETS OF THE SAME SECTION.

IS POLYCARBONATE PROTECTED FROM UV RAYS?

YES, THE SHEETS ARE PROTECTED FROM UV RAYS DURING THE PRODUCTION STAGE THANKS TO THE CO-EXTRUSION PROCESS.

DOES POLYCARBONATE COMPLY WITH EUROPEAN REGULATIONS ON ITS USE?

YES, IT MEETS THE QUALITY STANDARDS ESTABLISHED IN EU REGULATION 305/2011 FOR THE MARKETING OF CONSTRUCTION PRODUCTS. IN ADDITION ACCORDING TO THE EUROPEAN REGULATION EN 16153: 2013 ENTERED INTO FORCE ON 01/01/2015 IT IS MANDATORY TO AFFIX THE EC MARKING ON EACH ALVEOLAR POLYCARBONATE SHEETS.

WHY USING POLYCARBONATE?

- BECAUSE IT IS A TRANSPARENT MATERIAL LIKE GLASS, WHICH ALLOWS LIGHT TO PASS THROUGH IT CREATING PLEASANT CHROMATIC EFFECTS THANKS TO THE COLORING OF THE SHEETS AND MAINTAINING ENVIRONMENTAL COMFORT AND THERMAL INSULATION UNCHANGED.
- BECAUSE IT IS A STRONG MATERIAL, 250 TIMES MORE RESISTANT THAN GLASS. IT WITHSTANDS UV RAYS, ATMOSPHERIC AGENTS AND ACCIDENTAL IMPACTS EVEN AFTER PROLONGED EXPOSURE TO DIRECT SUNLIGHT.
- BECAUSE IT IS A LIGHTWEIGHT MATERIAL, MUCH MORE THAN GLASS. USING POLYCARBONATE IN THE CIVIL AND INDUSTRIAL BUILDING SECTOR MEANS REDUCING CONSTRUCTION COSTS AND KEEPING PRESSURE AND DEPRESSION LOAD VALUES UNCHANGED.
- BECAUSE IT IS AN INSULATING MATERIAL THAT MINIMIZES THE TRANSFER OF THERMAL ENERGY (SO-CALLED THERMAL INSULATION) AND SOUND ENERGY (SO-CALLED ACOUSTIC INSULATION).
- BECAUSE IT IS A SAFE MATERIAL, CHARACTERIZED BY THE SO-CALLED RESILIENCE THAT IS THE ABILITY TO ABSORB ELASTIC DEFORMATION ENERGY IN COMPLIANCE WITH SAFETY REGULATIONS FOR PUBLIC AND WORK ENVIRONMENTS.
- BECAUSE IT IS A VERSATILE MATERIAL WITH VERY LOW ENVIRONMENTAL IMPACT WHOSE USE ALLOWS CONSIDERABLE ENERGY SAVING. AT THE END OF THEIR LIFE CYCLE, THE SHEETS ARE 100% RECYCLABLE.

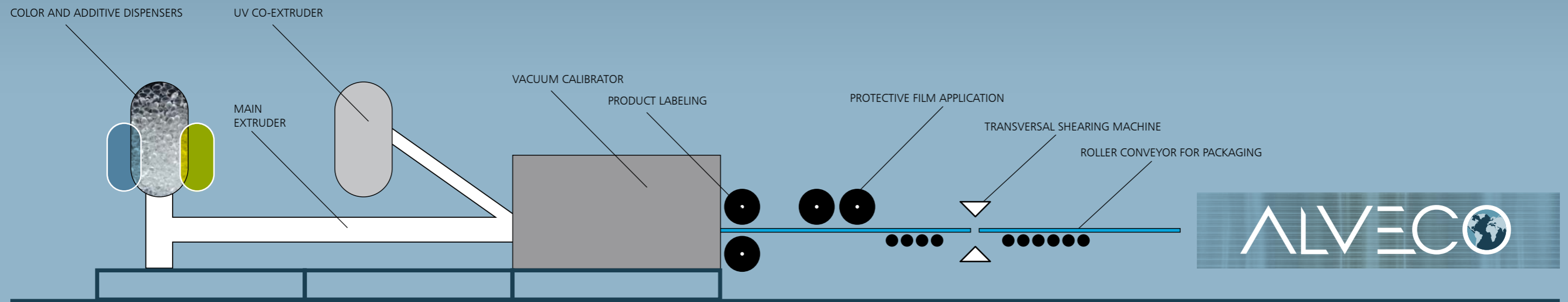

ALVE - ROOF 5G 40

10/16 mm

TRAPEZOIDAL SYSTEM IN MULTIWALL POLYCARBONATE

ALVE-ROOF 5G 40 IS A TRANSLUCENT COVERING ELEMENT IN POLYCARBONATE WHICH, THANKS TO ITS THERMAL INSULATION CHARACTERISTICS AND COUPLING WITH METAL ROOFS ALLOWS THE CONSTRUCTION OF SKYLIGHTS FROM RIDGE TO EAVES, SUITABLE TO GUARANTEE COMPLIANCE WITH REFERENCE REGULATIONS REGARDING ENERGY PERFORMANCE AND ILLUMINATING SURFACE OF BUILDINGS.

TECHNICAL SPECIFICATIONS

TRANSLUCENT ALVEOLAR POLYCARBONATE ROOF, UV PROTECTED, CO-EXTRUDED ON THE OUTER SIDE, MULTIWALL STRUCTURE, THICKNESS 10/16 mm, RIB HEIGHT 40 mm, OPAL CRYSTAL COLOR, ENDS CLOSED WITH HEAT-WELDING. DIMENSIONS: MODULE WIDTH 1,000 mm, LENGTH CUT TO SIZE.

Thickness	10 mm	16 mm
Rib height	40 mm	40 mm
Structure	Multialveolar 3 walls	Multialveolar 3 walls
Standard width	1.000 mm / Nom. 1.040 mm	1.000 mm / Nom. 1.040 mm
Standard length	Cut to size	Cut to size
Color	Crystal / Opal	Crystal / Opal
Light transmission	Crystal 62% / Opal 45%	Crystal 55% / Opal 37%
Thermal transmittance	U=2,80 W/m ² K	U=2,70 W/m ² K
Linear expansion	0,065 mm/m °C	0,065 mm/m °C
Operating temperature	-40°C + 120°C	-40°C + 120°C
Vicat	+151 °C	+151 °C
Cold bending radius	9000 mm	9000 mm
UV protection	Upper side	Upper side
Fire resistance certification EN 13501-1	B-s1,d0	B-s1,d0

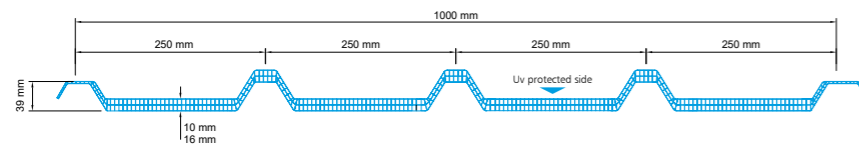

PERMISSIBLE LOADS ON MULTIPLE SUPPORTS

System resistance with evenly distributed load. The graph refers to a correct installation according to the Technical Manual.

THICKNESS 10 mm

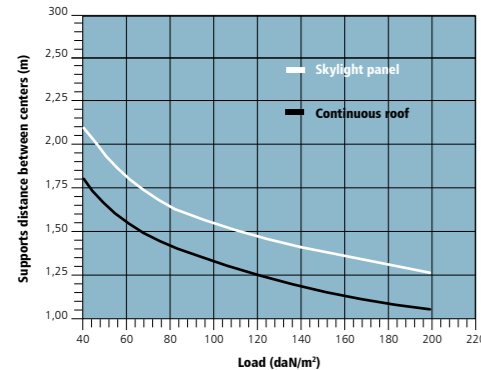

THICKNESS 16 mm

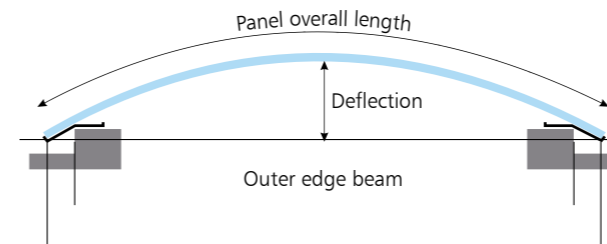
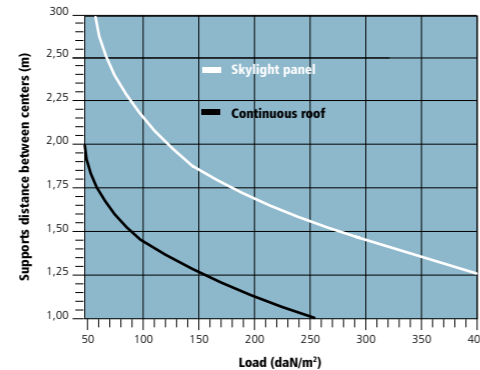

RADIUS 3.300 mm
MAXIMUM OVERALL LENGTH 5,000

RADIUS 6.000 mm
MAXIMUM OVERALL LENGTH 6,000

Span	Deflection	Overall Length	Deflection	Overall Length
1.000	38	1.016	21	1.008
1.200	55	1.221	30	1.210
1.400	75	1.428	41	1.413
1.600	98	1.636	54	1.615
1.800	125	1.845	68	1.819
2.000	155	2.057	84	2.023
2.200	189	2.270	102	2.227
2.400	226	2.486	121	2.432
2.600	267	2.705	143	2.638
2.800	312	2.927	166	2.845
3.000	361	3.152	191	3.052
3.200	414	3.381	217	3.261
3.400	472	3.615	246	3.470
3.600	534	3.854	276	3.681
3.800	602	4.098	309	3.892
4.000	675	4.349	343	4.105
4.200	754	4.608	380	4.319
4.400	840	4.875	418	4.535
4.600	934	5.151	458	4.752



PERMISSIBLE LOADS ON 2 SUPPORTS

System resistance with evenly distributed load. The graph refers to a correct installation according to the Technical Manual.

THICKNESS 10 mm

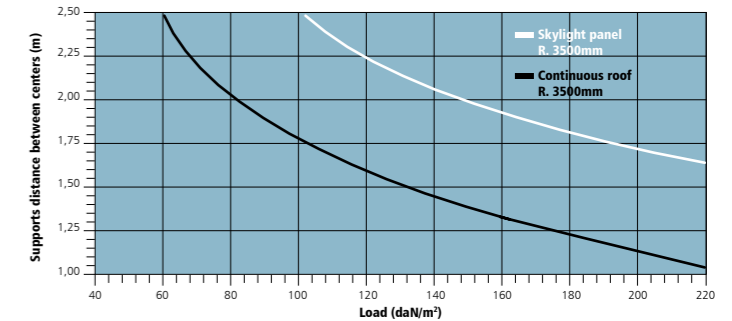

THICKNESS 16 mm

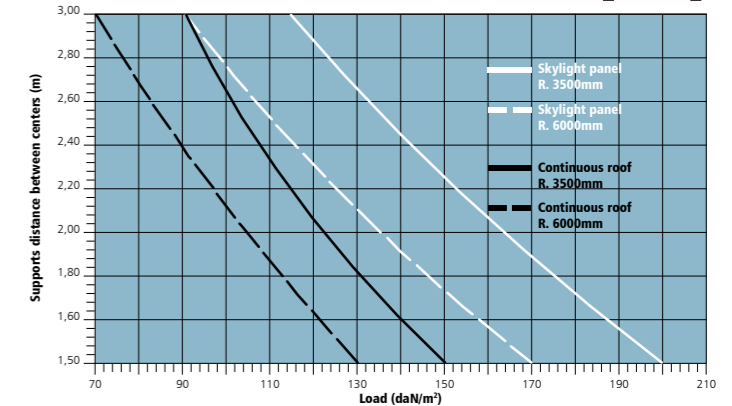

ACCESSORIES:

Variable ridge

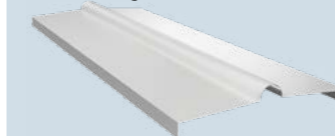

Upper bird-screen ridge



Lower bird-screen Ridge eaves



Variable length screw



Stainless steel washer with EPDM gasket

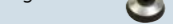



ALVE - ROOF 4G 80

12/16/20/25 mm

TRAPEZOIDAL SYSTEM IN MULTIWALL POLYCARBONATE

ALVE-ROOF 4G 80 IS A TRANSLUCENT POLYCARBONATE COVERING ELEMENT THAT, THANKS TO ITS THERMAL INSULATION CHARACTERISTICS AND COUPLING WITH METAL ROOFS, ALLOWS THE CONSTRUCTION OF SKYLIGHTS FROM RIDGE TO EAVES THAT ARE SUITABLE FOR GUARANTEEING COMPLIANCE WITH REFERENCE REGULATIONS REGARDING ENERGY PERFORMANCE AND ILLUMINATING SURFACE OF BUILDINGS. THE SECTION OF THIS PANEL, THANKS TO THE HEIGHT OF THE CORRUGATION OF 80 MM, GIVES THE PRODUCT HIGH LOAD RESISTANCE

TECHNICAL SPECIFICATIONS

A TRANSLUCENT COVERING IN ALVEOLAR POLYCARBONATE, UV-PROTECTED BY COEXTRUSION ON THE OUTSIDE, MULTIALVEOLAR STRUCTURE, THICKNESS 12/16/20/25 MM, RIB HEIGHT 80 MM, CRYSTAL OR OPAL COLOR, CLOSING OF THE HEADS WITH THERMOWELDING. THE DIMENSIONS ARE A WIDTH OF 1,000 MM PER MODULE AND A LENGTH THAT CAN BE CUSTOMIZED.

Thickness	12 mm	16 mm	20 mm	25 mm
Rib height	80 mm	80 mm	80 mm	80 mm
Structure	Multialveolar 5 walls	Multialveolar 5 walls	Multialveolar 5 walls	Multialveolar 5 walls
Standard width	1.000 mm / Nom. 1.074 mm	1.000 mm / Nom. 1.074 mm	1.000 mm / Nom. 1.074 mm	1.000 mm / Nom. 1.074 mm
Length massima	13000 mm	13000 mm	13000 mm	13000 mm
Color	Crystal / Opal	Crystal / Opal	Crystal / Opal	Crystal / Opal
Light transmission	Crystal 70% / Opal 52% ±5%	Crystal 68% / Opal 50% ±5%	Cristallo 66% / Opale 48% ±5%	Cristallo 62% / Opale 46% ±5%
Thermal transmittance	U=2,40 W/m² K	U=2,20 W/m² K	U=2,00 W/m² K	U=1,80 W/m² K
Linear expansion	0,065 mm/m °C (6.5 x 10-5 1/°C)	0,065 mm/m °C (6.5 x 10-5 1/°C)	0,065 mm/m °C (6.5 x 10-5 1/°C)	0,065 mm/m °C (6.5 x 10-5 1/°C)
Operating temperature	-40°C + 120°C	-40°C + 120°C	-40°C + 120°C	-40°C + 120°C
Vicat	+151 °C	+151 °C	+151 °C	+151 °C
Fire resistance certification EN 13501-1	B-s1,d0	B-s1,d0	B-s1,d0	B-s1,d0
UV protection	Upper side	Upper side	Upper side	Upper side

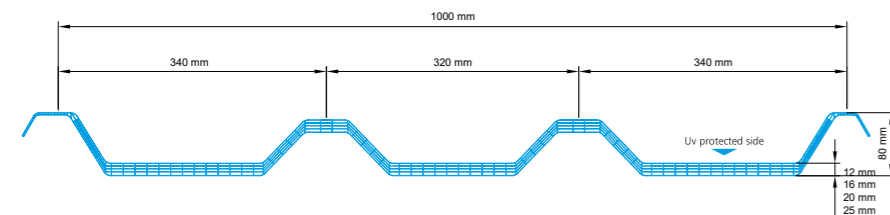

REQUEST THE LOAD TECHNICAL SHEET FOR EACH PRODUCT

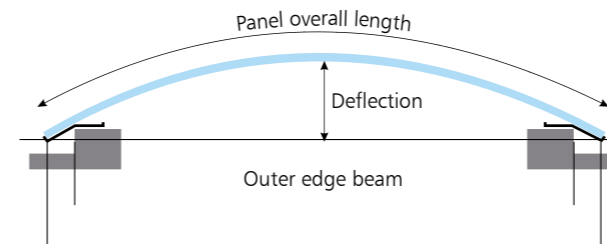

Span	RADIUS 3.300 mm MAXIMUM OVERALL LENGTH 5,000		RADIUS 6.000 mm MAXIMUM OVERALL LENGTH 6,000	
	Deflection	Overall Length	Deflection	Overall Length
1.000	38	1.016	21	1.008
1.200	55	1.221	30	1.210
1.400	75	1.428	41	1.413
1.600	98	1.636	54	1.615
1.800	125	1.845	68	1.819
2.000	155	2.057	84	2.023
2.200	189	2.270	102	2.227
2.400	226	2.486	121	2.432
2.600	267	2.705	143	2.638
2.800	312	2.927	166	2.845
3.000	361	3.152	191	3.052
3.200	414	3.381	217	3.261
3.400	472	3.615	246	3.470
3.600	534	3.854	276	3.681
3.800	602	4.098	309	3.892
4.000	675	4.349	343	4.105
4.200	754	4.608	380	4.319
4.400	840	4.875	418	4.535
4.600	934	5.151	458	4.752

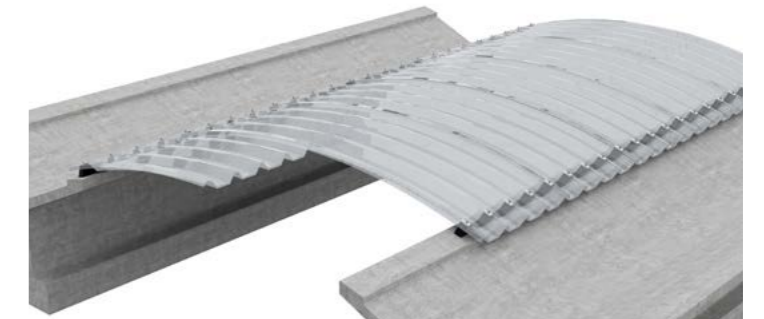

ACCESSORIES:

Variable ridge

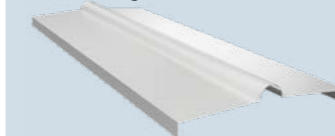

Upper bird-screen ridge



Lower bird-screen Ridge eaves



Variable length screw



Stainless steel washer with EPDM gasket





ALVE - ROOF 2G - 30/40 FULL

TRAPEZOIDAL SYSTEM IN MULTIWALL POLYCARBONATE

ALVE-ROOF 2G-30/40 FULL IS A TRANSLUCENT COVERING ELEMENT IN POLYCARBONATE WHICH, THANKS TO ITS THERMAL INSULATION CHARACTERISTICS AND COUPLING WITH METAL ROOFS ALLOWS THE CONSTRUCTION OF SKYLIGHTS FROM RIDGE TO EAVES, SUITABLE TO GUARANTEE COMPLIANCE WITH REFERENCE REGULATIONS REGARDING ENERGY PERFORMANCE AND ILLUMINATING SURFACE OF BUILDINGS. THANKS TO THE NUMBER OF ALVEOLI PRESENT IN THE MALE CONNECTION JOINT, THE CONDENSATION-CAUSING THERMAL BRIDGE IS NOT IN USE.

TECHNICAL SPECIFICATIONS

TRANSLUCENT COVER IN ALVEOLAR POLYCARBONATE, WITH MULTIWALL MALE CONNECTION JOINT, UV PROTECTED, CO-EXTRUDED ON THE OUTER SIDE, 8-WALLS STRUCTURE, 30/40 mm THICK, RIB HEIGHT 70/80 mm, CRYSTAL OR OPAL COLOR, ENDS CLOSED WITH ADHESIVE ALUMINUM TAPE.

DIMENSIONS: MODULE WIDTH 1,000 mm, LENGTH CUT TO SIZE.

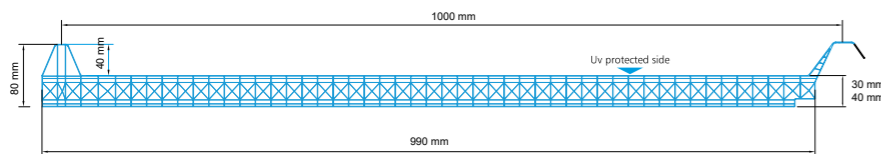

THICKNESS 40 mm

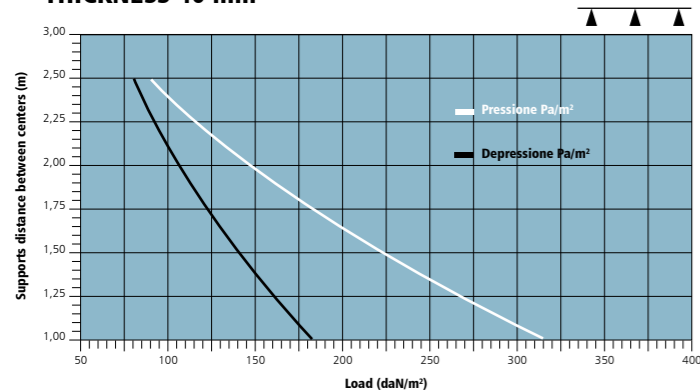

PERMISSIBLE LOADS ON MULTIPLE SUPPORTS
System resistance with evenly distributed load. The graph refers to a correct installation according to the Technical Manual.

Rib height	30 mm	40 mm
Structure	Multialveolar 8 walls	Multialveolar 8 walls
Standard width	1.000 mm	1.000 mm
Standard length	Cut to size max 13500 mm	Cut to size max 13500 mm
Color	Crystal / Opal	Crystal / Opal
Light transmission	Crystal 52%±3 / Opal 37 %±3	Crystal 50%±3 / Opal 35% ±3
Solar factor	Crystal 57%±3 / Opal 43%±3	Crystal 55% ±3 / Opal 40% ±3
Shadow coefficient	Crystal 64%±3 / Opal 48 %±3	Crystal 63%±3 / Opal 46 %±3
Thermal transmittance	U=1,30 W/m² K	U=1,10 W/m² K
Linear expansion	0,065 mm/m °C (6.5 x 10 ⁻⁵ 1/°C)	0,065 mm/m °C (6.5 x 10 ⁻⁵ 1/°C)
Operating temperature	-40°C + 120°C	-40°C + 120°C
Vicat	+151 °C	+151 °C
UV protection	Upper side	Upper side
Fire resistance certification EN 13501-1	B-s1,d0	B-s1,d0

ACCESSORIES:

Variable ridge

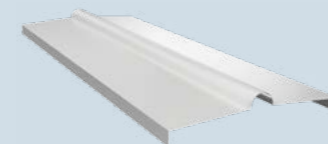

Upper bird-screen ridge



Variable length screw



Stainless steel washer with EPDM gasket



Alveoli closure with U-shaped section in polycarbonate

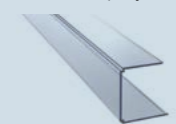

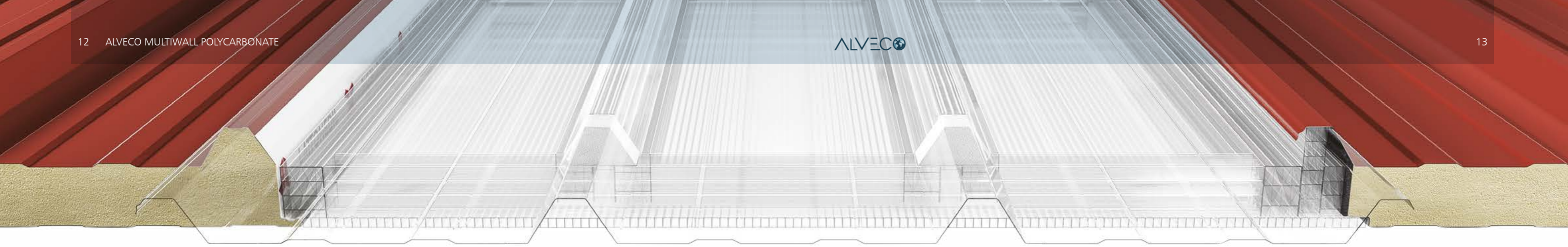

ALVELUMIERE

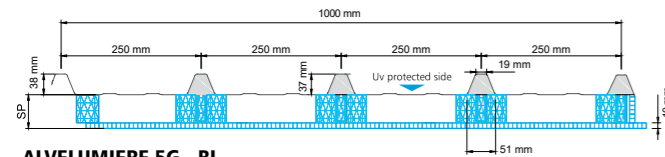

ALVELUMIERE 5G - BI

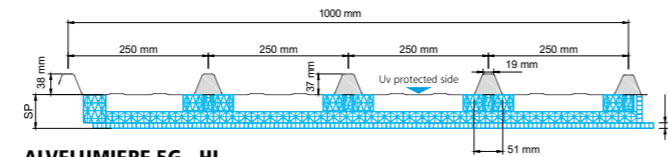

ALVELUMIERE 5G - HI

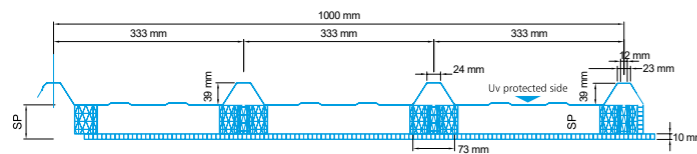

ALVELUMIERE 4G - BI

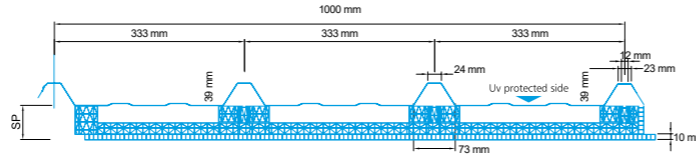

ALVELUMIERE 4G - HI

THE ALVELUMIERE 4G / 5G SYSTEM OPTIMISES LIGHT DIFFUSION WITHIN THE STRUCTURE IMPROVING PEOPLE'S WELL-BEING AND ENERGY SAVINGS. IT IS A UNIQUE SYSTEM ON THE MARKET, CONSISTING OF EXTRUDED POLYCARBONATE REINFORCEMENTS, WHICH REMAIN RIGID AND MAINTAIN THEIR CHARACTERISTICS OVER TIME.

ALVELUMIERE 4G / 5G POLYCARBONATE ALLOWS YOU TO FIND THE SYSTEM THAT IS MOST SUITABLE FOR YOUR NEEDS.

ALVELUMIERE 4G / 5G POLYCARBONATE PANELS ARE PRODUCED IN TWO VERSIONS (4G / 5G - BI AND 4G / 5G - HI):

THE UPPER SIDE IS MADE OF 1 mm THICK COMPACT POLYCARBONATE (ACCORDING TO EN-1013), WHILE THE LOWER SIDE IS MADE OF 10 mm THICK HONEYCOMB POLYCARBONATE. THE UPPER AND LOWER FACES ARE COUPLED BY EXTRUDED POLYCARBONATE HONEYCOMB PROFILES. MOREOVER, POLYCARBONATE 4G / 5G - HI IS AN EVEN MORE INSULATING PANEL SYSTEM FOR GREATER THERMAL COMFORT. THIS ALSO RESULTS IN INCREASED LOAD-BEARING CAPACITY AND EASIER INSTALLATION, BOTH FOR NEW CONSTRUCTIONS OR RENOVATIONS.

AVAILABLE THICKNESS: 30-40-50-60-80-100-120-150-160-180-200 mm.

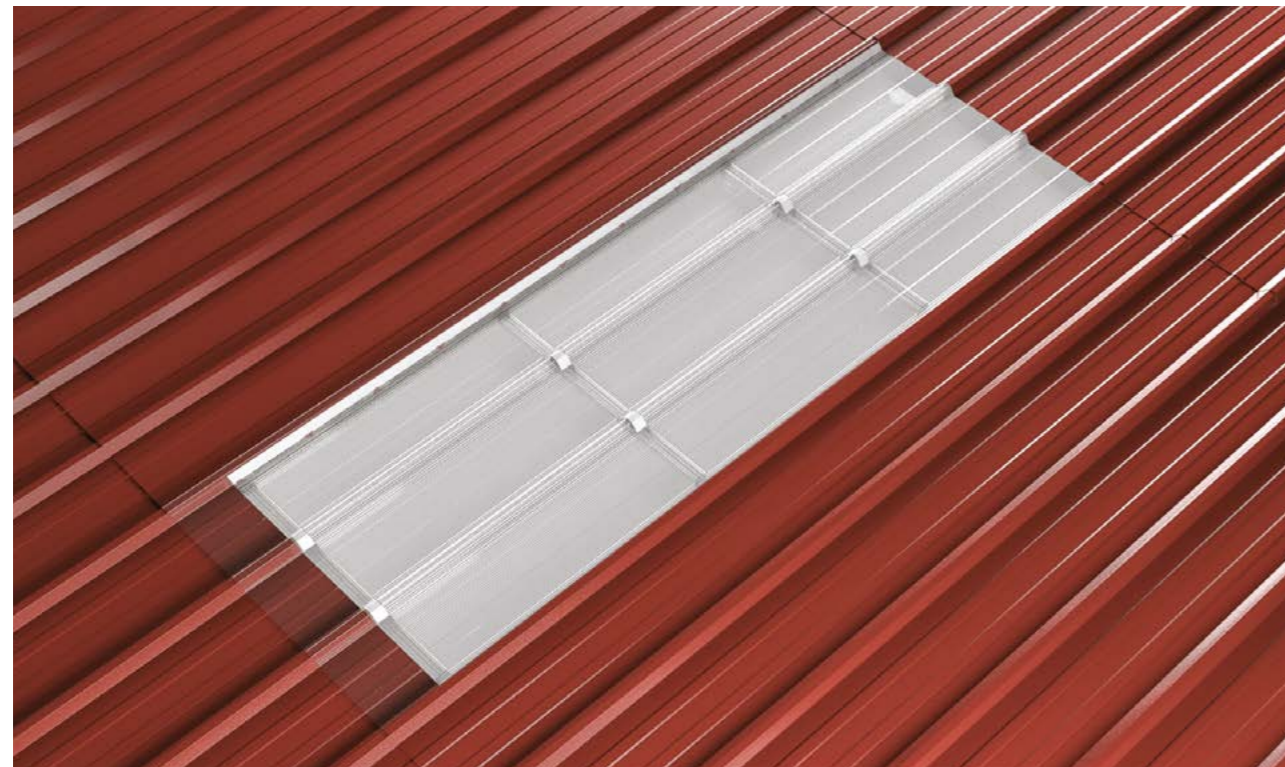

	ALVELUMIERE 4G/5G - BI	ALVELUMIERE 4G/5G - HI
Utilization	Natural lighting of insulated roofs and cladding	Natural lighting of insulated roofs and cladding
Length	from 1,50 m a 6,50 m	from 1,50 m to 6,50 m
Thickness	30, 40, 50, 60, 80, 100, 120, 150, 160, 180, 200 mm	30, 40, 50, 60, 80, 100, 120, 150, 160, 180, 200 mm
External finish	UV protection	UV protection
Color	Crystal or Opal	Crystal or Opal
Fire resistance certification EN 13501-1	B-s1,d0	B-s1,d0
Light transmission	Opal 65% / Crystal 75%	Opal 35% / Crystal 40%
Operating temperature	-40°C to +110°C	-40°C to +110°C
Warranty	10 years	10 years
Thermal transmittance U	U to 2,36 W/m².K	Up to 1,02 W/m².K

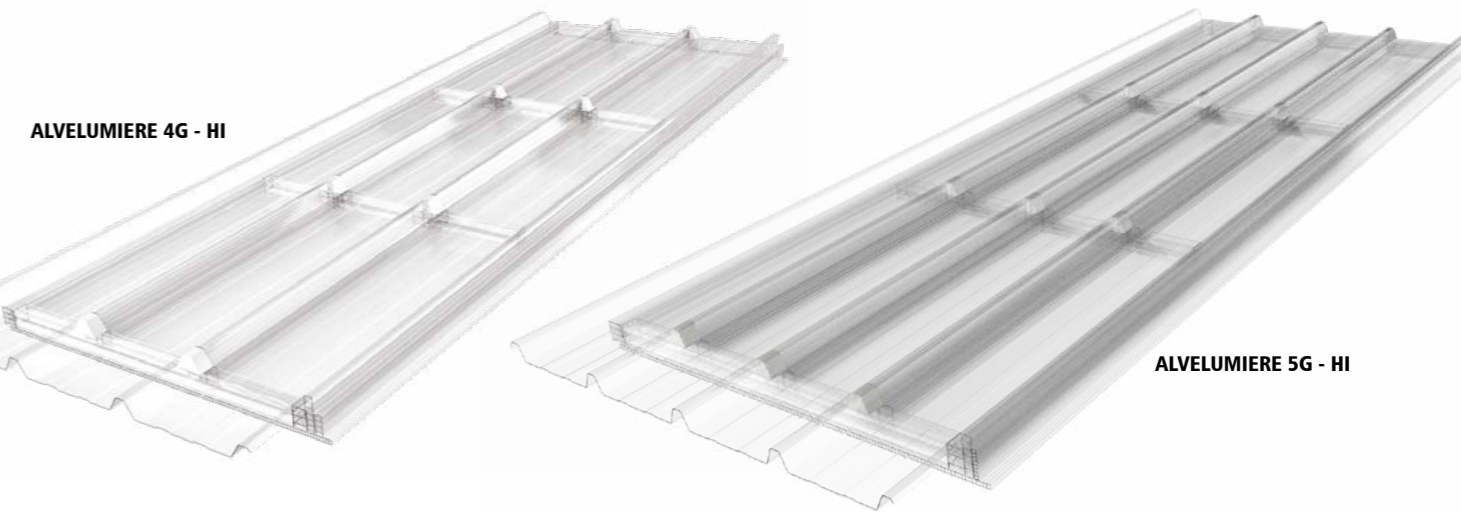

ALVELUMIERE 4G - HI

ALVELUMIERE 5G - HI

ALVE - ROOF ONDA

4/6 mm

SINUSOIDAL MULTIWALL SYSTEM IN POLYCARBONATE

ALVE-ROOF ONDA_4/6 mm IS A TRANSLUCENT COVERING ELEMENT IN POLYCARBONATE WHICH IS USED FOR THE CONSTRUCTION OF SKYLIGHTS AND IT IS COMPATIBLE WITH THE 177/51 PROFILE IN FIBER-CEMENT. ITS PARTICULAR GEOMETRY GIVES THE PRODUCT HIGH FLEXIBILITY OF APPLICATION, BOTH AS AN INTRA-PITCH SKYLIGHT, AS A SKYLIGHT FROM RIDGE TO EAVES, AND AS A COMPLETELY TRANSPARENT ROOF.

TECHNICAL SPECIFICATIONS

TRANSLUCENT ROOF IN 4/6 mm THICK ALVEOLAR POLYCARBONATE, UV PROTECTED, CO-EXTRUDED ON THE OUTER SIDE, CRYSTAL OR OPAL COLOR, ENDS SEALED WITH HEAT-WELDING. DIMENSIONS: MODULE WITH VARIABLE WIDTH 1,097 mm, LENGTH CUT TO SIZE.

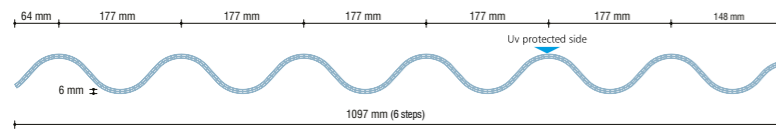

Thickness	4 mm	6 mm
Step height	51 mm	51 mm
Step passage	177 mm	177 mm
Standard width	1.050 mm (875 mm on request)	1.050 mm (875 mm on request)
Standard length	5.000 mm (max recommended)	5.000 mm (max recommended)
Color	Crystal / Opal	Crystal / Opal
Light transmission	Crystal 80% / Opal 70%	Crystal 73% / Opal 50%
Acoustic insulation	16 dB	16 dB
Thermal transmittance	U=3,70 W/m² K	U=3,30 W/m² K
Linear expansion	0,065 mm/m °C	0,065 mm/m °C
Operating temperature	-40°C + 120°C	-40°C + 120°C
Fire resistance certification EN 13501-1	B-s1,d0	B-s1,d0

PERMISSIBLE LOADS ON MULTIPLE SUPPORTS

System resistance with evenly distributed load. The graph refers to a correct installation according to the Technical Manual.

THICKNESS 4/6 mm

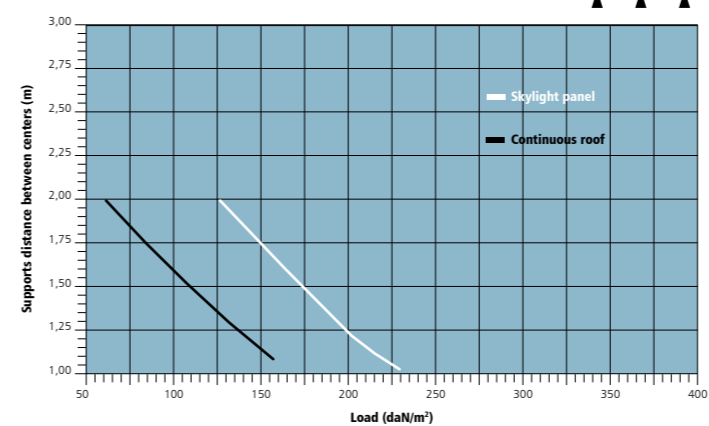

PERMISSIBLE LOADS ON 2 SUPPORTS

System resistance with evenly distributed load. The graph refers to a correct installation according to the Technical Manual.

THICKNESS 4/6 mm

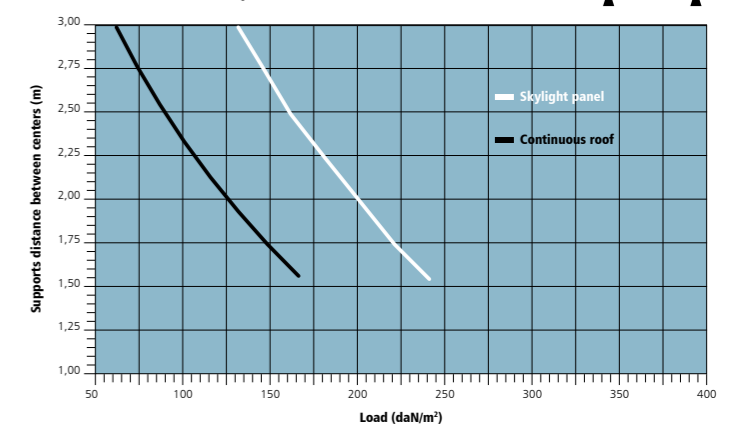

ACCESSORIES:

Variable ridge

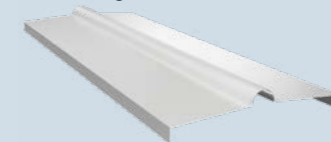

Upper bird-screen ridge



Lower bird-screen Ridge eaves



Variable length screw



Stainless steel washer with EPDM gasket



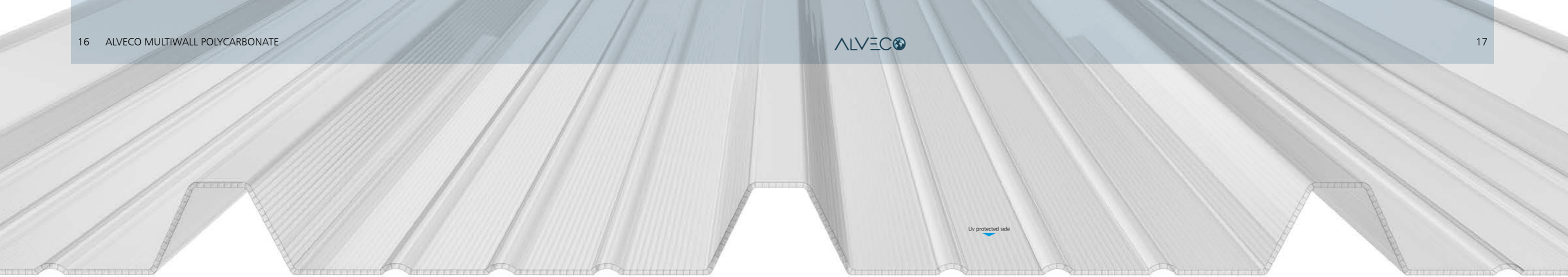

ALVE-ROOF 5G 2.5

TRAPEZOIDAL MULTIWALL POLYCARBONATE ROOFLIGHTS

ALVE-ROOF 5G 2.5 IS A TRANSLUCENT COVERING ELEMENT IN MICRO-ALVEOLAR POLYCARBONATE PRODUCED FOR ALL SECTIONS OF POLYURETHANĒ PANELS AND TRAPEZOIDAL SHEETS ON THE MARKET. ITS PARTICULAR GEOMETRY GIVES THE PRODUCT HIGH FLEXIBILITY OF APPLICATION, BOTH AS AN INTRA-PITCH SKYLIGHT, AS A SKYLIGHT FROM RIDGE TO EAVES, AND AS A COMPLETELY TRANSPARENT ROOF.

TECHNICAL SPECIFICATIONS

TRANSLUCENT ROOF IN COMPACT POLYCARBONATE, UV PROTECTED, CO-EXTRUDED ON THE OUTER SIDE, 2-WALLS ALVEOLAR STRUCTURE, 2.5 mm THICK, ENDS SEALED WITH HEAT-WELDING. DIMENSIONS: MODULE WITH VARIABLE WIDTH 1,000/1,240 mm, LENGTH CUT TO SIZE

Thickness	2,5 mm
Structure	Two walls
Thermal transmittance	U= 4,6 W/m²K
Color	Crystal / Opal
Light transmission	Crystal 85% / Opal 70%
Linear expansion	0,0650 mm/m°C
Operating temperature	-30°C + 120°C
Fire resistance certification EN 13501-1	B-s1,d0

REQUEST THE LOAD TECHNICAL SHEET FOR EACH PRODUCT

AVAILABLE IN DIFFERENT SHAPE,
THEY MATCH PERFECTLY WITH A WIDE RANGE OF SHEET METAL PROFILES.

Uv protected side

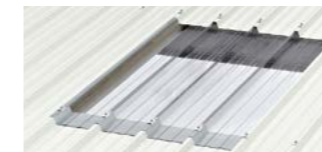

Greenhouse covers



Transversal skylight



Eaves to ridge skylight

ACCESSORIES:

Variable ridge

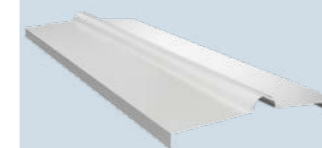

Upper bird-screen ridge



Lower bird-screen Ridge eaves

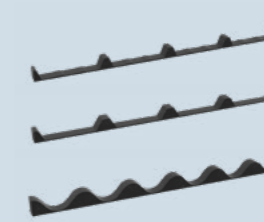

Variable length screw



Stainless steel washer with EPDM gasket



ALVE-ROOF 5G 2.5

TRAPEZOIDAL MULTIWALL POLYCARBONATE ROOFLIGHTS

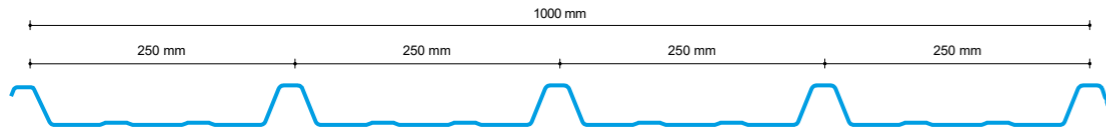

5 RIBS PROFILES COMPATIBLE WITH:

- ADRIA ROOF
- ALUBEL DACH
- ISOLPACK DELTA 5
- ISOLPACK RW 1000
- ISOPAN ISOCOP
- ITALPANNELLI PENTA 01
- LANDINI H40
- LATTONEDIL EUROCINQUE
- LATTONEDIL EUROFIRE
- LATTONEDIL TT40
- MARCEGAGLIA TD5
- MARCEGAGLIA BROLLO 740
- SANDRINI SAND40/250
- SILEX

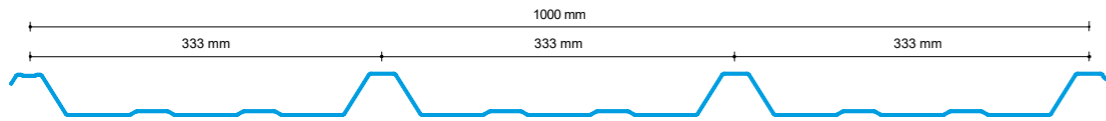

4 RIBS PROFILES COMPATIBLE WITH:

- LATTONEDIL EUROCOPE
- ISOLPACK R4

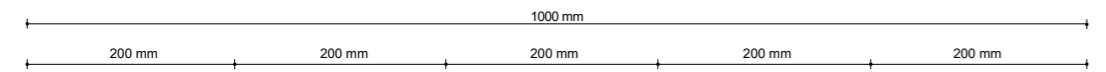

6 RIBS PROFILES COMPATIBLE WITH:

- LATTONEDIL ISOCOPRE
- SILMA 6
- MARCEGAGLIA EGB 401 6 RIBS 915

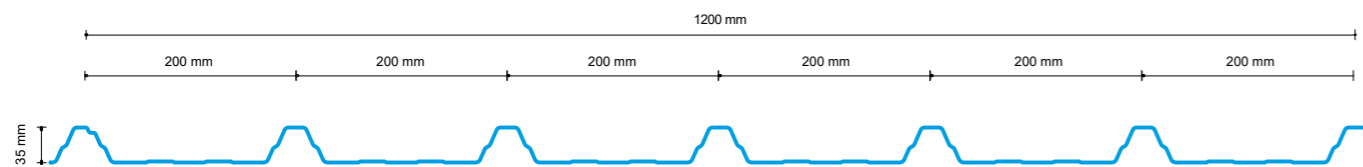

7 RIB PROFILES COMPATIBLE WITH:

- SANDRINI SAND 35 5/6/7 RIBS

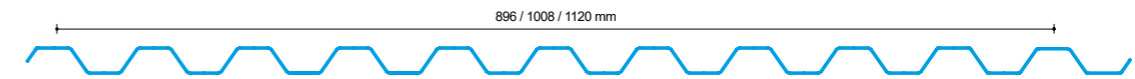
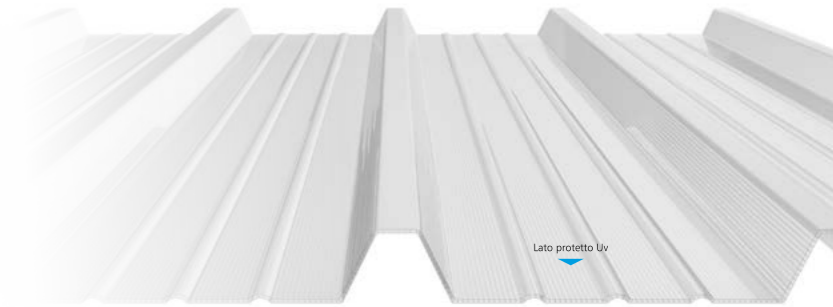

CORRUGATED PROFILES COMPATIBLE WITH:

- ALUBEL 28
- EDILFIBRO
- LATTONEDIL TT 28
- SANDRINI LAND 28

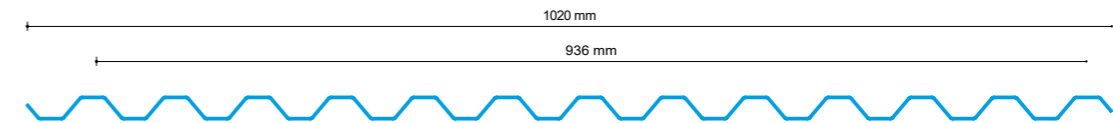

CORRUGATED PROFILES COMPATIBLE WITH:

- ALUBEL 21

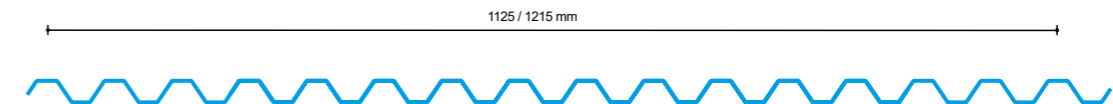

CORRUGATED PROFILES COMPATIBLE WITH:

- 20/75 PROFILE

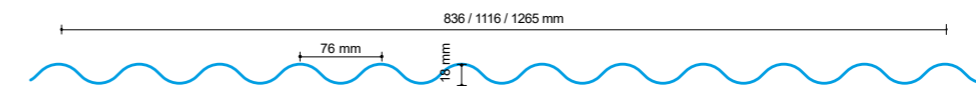

SINUSOIDAL PROFILES COMPATIBLE WITH:

- ONDA 76 -18_9 TO 18 WAVES_608 mm TO 1216 mm

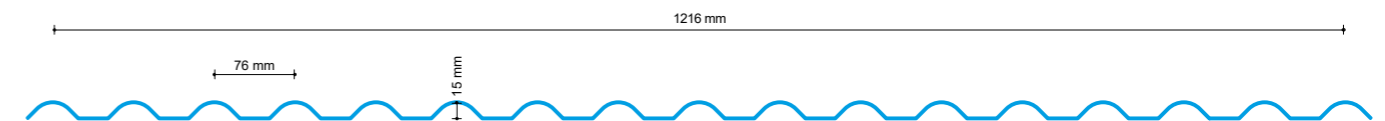

OMEGA PROFILES COMPATIBLE WITH:

- OMEGA 76 15

ALVECOMP-ROOF 0,8 / 1,0 / 1,2

TRAPEZOIDAL SHEETS IN COMPACT POLYCARBONATE THICKNESS 0,8 / 1,0 / 1,2 mm

IT IS A TRANSLUCENT COVERING ELEMENT IN COMPACT POLYCARBONATE, PRODUCED FOR ALL SECTIONS OF POLYURETHANE PANELS AND TRAPEZOIDAL SHEETS ON THE MARKET. THE PARTICULAR GEOMETRY GIVES THE PRODUCT HIGH FLEXIBILITY OF APPLICATION, BOTH AS AN INTRA-PITCH SKYLIGHT, AS A SKYLIGHT FROM RIDGE TO EAVES, AND AS A COMPLETELY TRANSPARENT ROOF.

TECHNICAL SPECIFICATIONS

TRANSLUCENT ROOF IN COMPACT POLYCARBONATE, UV-PROTECTED, CO-EXTRUDED ON THE OUTER SIDE, VARIABLE THICKNESS OF 0,8 / 1,0 / 1,2 mm, CRYSTAL OR OPAL COLOR.
DIMENSIONS: MODULE WITH VARIABLE WIDTH 1,000/1,240 MM, LENGTH CUT TO SIZE.

Thickness	0,8 / 1,0 / 1,2 mm
Thermal transmittance	5,7 W/m ² K
Color	Crystal / Opal
Light transmission	Crystal 85% - Opal 70%
Linear Expansion	0,0650 mm/m°C
Operating temperature	-30°C + 120°C
Fire resistance certification EN 13501-1	B-s1,d0

REQUEST THE LOAD TECHNICAL SHEET FOR EACH PRODUCT

ALVECOMP-ROOF SHEETS 0,8 / 1,0 / 1,2 mm MUST BE FASTENED IN CORRESPONDENCE OF THE STRUCTURES ON EACH UPPER PORTION OF THE RIB, WITH Ø 6.3 MM SCREWS, EQUIPPED OF THE PROVIDED GASKETS. THE USE OF OTHER TYPES OF FASTENERS CAN ALTER THE SHEET RESISTANCE. FOR FASTENING, IT IS RECOMMENDED PRE-DRILLING WITH A METAL DRILL BIT WITH A DIAMETER 2 mm BIGGER THAN THAT OF THE SCREW. OVER TIGHTENING OF THE FASTENING ELEMENTS PREVENTS THE MOVEMENT OF THE SHEETS DUE TO THERMAL EXPANSION, COMPROMISING THEIR INTEGRITY.

AVAILABLE IN DIFFERENT SHAPES AND THICKNESSES,
THEY MATCH PERFECTLY WITH A WIDE RANGE OF SHEET METAL PROFILES.

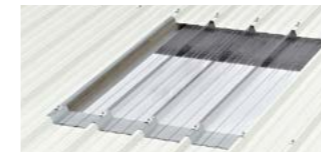

Uv protected side



Greenhouse covers



Transversal skylight

Eaves to ridge skylight

ACCESSORIES:

Variable ridge

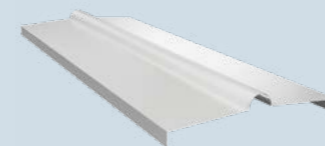

Upper bird-screen ridge

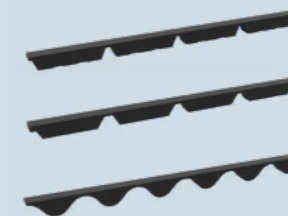

Lower bird-screen Ridge eaves

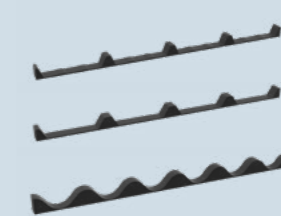

Variable length screw



Stainless steel washer with EPDM gasket



ALVECOMP-ROOF 0,8 / 1,0 / 1,2

TRAPEZOIDAL SHEETS IN COMPACT POLYCARBONATE THICKNESS 0,8 / 1,0 / 1,2 mm

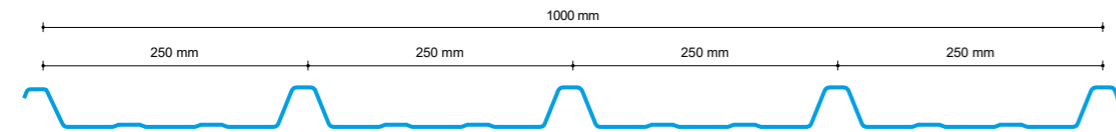

5 RIBS PROFILES COMPATIBLE WITH:

- ADRIA ROOF
- ALUBEL DACH
- ISOLPACK DELTA 5
- ISOLPACK RW 1000
- ISOPAN ISOCOP
- ITALPANNELLI PENTA 01
- LANDINI H40
- LATTONEDIL EUROCINQUE
- LATTONEDIL EUROFIRE
- LATTONEDIL TT40
- MARCEGAGLIA TD5
- MARCEGAGLIA BROLLO 740
- SANDRINI SAND40/250
- SILEX

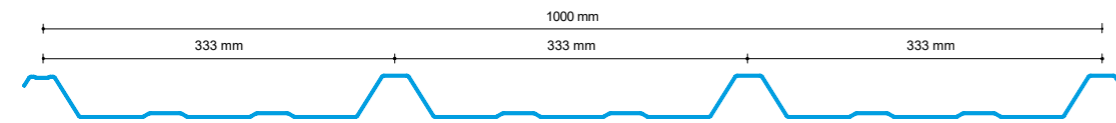

4 RIBS PROFILES COMPATIBLE WITH:

- LATTONEDIL EUROCOPRE
- ISOLPACK R4

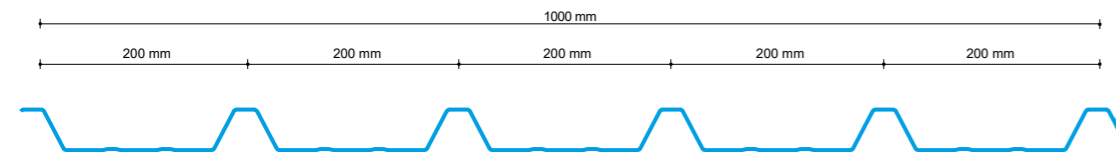

6 RIBS PROFILES COMPATIBLE WITH:

- LATTONEDIL ISOCOPRE
- SILMA 6
- MARCEGAGLIA EGB 401 6 RIBS 915

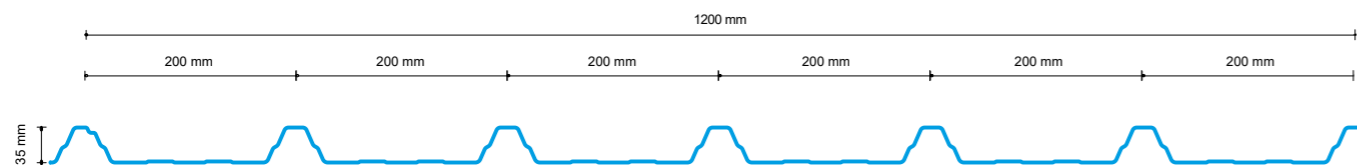

7 RIB PROFILES COMPATIBLE WITH:

- SANDRINI SAND 35 5/6/7 RIBS

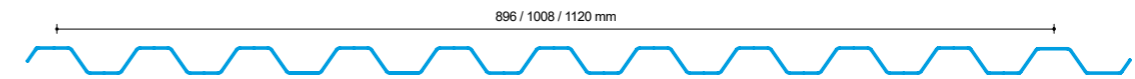

CORRUGATED PROFILES COMPATIBLE WITH:

- ALUBEL 28
- EDILFIBRO
- LATTONEDIL TT 28
- SANDRINI LAND 28

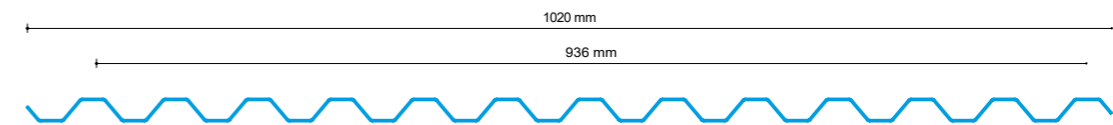

CORRUGATED PROFILES COMPATIBLE WITH:

- ALUBEL 21

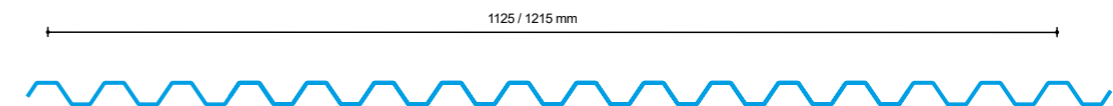

CORRUGATED PROFILES COMPATIBLE WITH:

- 20/75 PROFILE

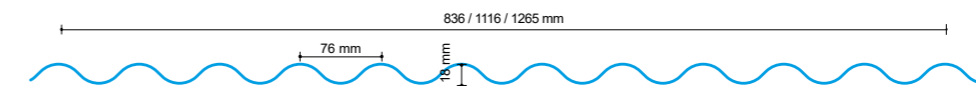

SINUSOIDAL PROFILES COMPATIBLE WITH:

- ONDA 76 -18_9 TO 18 WAVES_608 mm TO 1216 mm

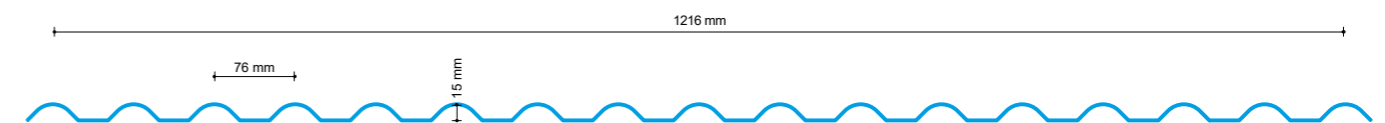

OMEGA PROFILES COMPATIBLE WITH:

- OMEGA 76 15

ALVECOMP-ROOF ICE

CORRUGATED POLYCARBONATE SHEETS WITH A THICKNESS OF 1.5 mm CERTIFIED FOR HAIL RESISTANCE ACCORDING TO UNI 10890:2000 STANDARD

IT IS A TRANSLUCENT COVERING ELEMENT IN COMPACT POLYCARBONATE WITH THICKNESSES FROM 1.5 UP TO 2 mm, PRODUCED FOR ALL SECTIONS OF POLYURETHANE PANELS AND TRAPEZOIDAL SHEETS ON THE MARKET. THE PARTICULAR GEOMETRY GIVES THE PRODUCT HIGH FLEXIBILITY OF APPLICATION, BOTH AS AN INTRA-PITCH SKYLIGHT, AS A SKYLIGHT FROM RIDGE TO EAVES, AND AS A COMPLETELY TRANSPARENT ROOF.

TECHNICAL SPECIFICATIONS

TRANSLUCENT ROOF IN COMPACT POLYCARBONATE, UV-PROTECTED, CO-EXTRUDED ON THE OUTER SIDE, VARIABLE THICKNESS OF 1,5 / 2,0 mm, CRYSTAL OR OPAL COLOR.
 DIMENSIONS: MODULE WITH VARIABLE WIDTH 1,000 mm, LENGTH 6000 mm (RECOMMENDED MAXIMUM)

RESISTANCE TO HAIL CLASS 34 B according to UNI 10890:2000

RESISTANCE SPEED LIMIT 34 M/S
 CONDITIONING TYPE B (CRUSHED ICE)

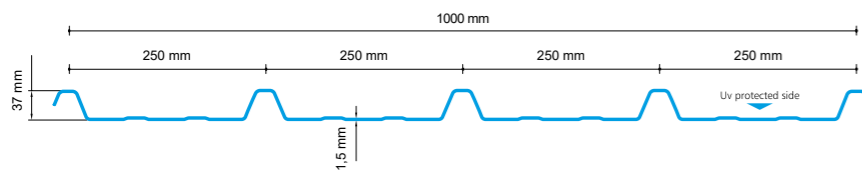
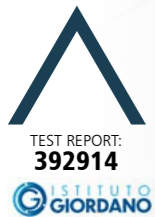

REQUEST THE LOAD TECHNICAL SHEET



Greenhouse covers

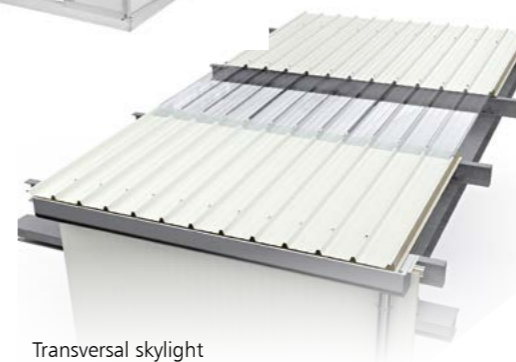
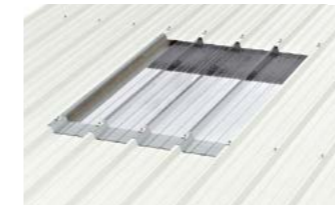

Transversal skylight



Eaves to ridge skylight

Thickness	1,5 / 2 mm
Standard width	1.000 mm / Nominale 1.035 mm
Length	6.000 mm / recommended maximum
Thermal transmittance	5,40 / 5,60 W/m²K
Color	Crystal / Opal
Light transmission	Crystal 80% - Opal 65%
Linear Expansion	0,065 mm/m°C
Minimum bending radius	9000 mm
UV protection	Upper side
Water absorption	±0.19% ASTM D570
Operating temperature	-30°C + 120°C
Fire resistance certification EN 13501-1	B-s1,d0

ACCESSORIES:

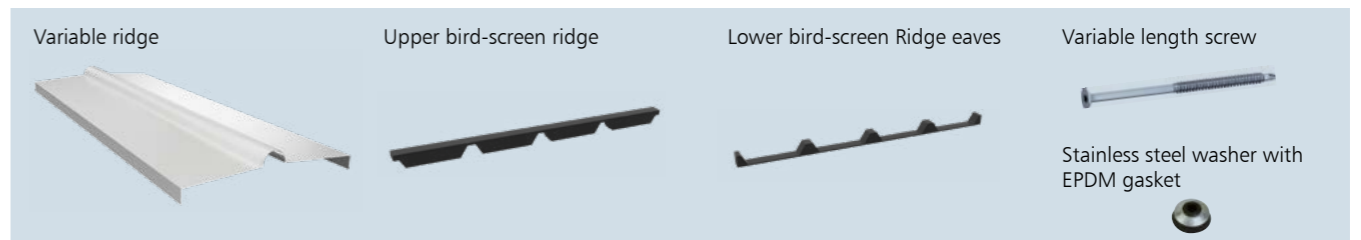

ALVECOMP-ROOF ICE SHEETS MUST BE FASTENED IN CORRESPONDENCE OF THE STRUCTURES ON EACH UPPER PORTION OF THE RIB, WITH Ø 6.3 MM SCREWS, EQUIPPED OF THE PROVIDED GASKETS. THE USE OF OTHER TYPES OF FASTENERS CAN ALTER THE SHEET RESISTANCE. FOR FASTENING, IT IS RECOMMENDED PRE-DRILLING WITH A METAL DRILL BIT WITH A DIAMETER 2 MM BIGGER THAN THAT OF THE SCREW. OVER TIGHTENING OF THE FASTENING ELEMENTS PREVENTS THE MOVEMENT OF THE SHEETS DUE TO THERMAL EXPANSION, COMPROMISING THEIR INTEGRITY.

ALVE - ROOF VELARIO 3 WALLS NO UV

10 mm

MALE FEMALE INTERLOCKING SYSTEM IN MULTIWALL POLYCARBONATE FOR FALSE CEILINGS

ALVE-ROOF VELARIO 3-WALLS IS RECOMMENDED FOR THE CONSTRUCTION OF FALSE CEILINGS, CURTAINS, INTERNAL DIVIDERS AND IN ALL THOSE SOLUTIONS NOT SUBJECTED TO THE DIRECT ACTION OF SUNLIGHT. PRACTICALITY AND COST-EFFECTIVENESS MAKE IT THE WINNING SOLUTION WHERE THE FOLLOWING IS REQUIRED:

- EXTRA-LIGHTWEIGHT
- HIGH IMPACT RESISTANCE
- HIGH LIGHT TRANSMISSION
- GOOD THERMAL INSULATION

THE SPECIAL INTERLOCKING SYSTEM FACILITATES INSTALLATION AND MAKES IT POSSIBLE TO IMPLEMENT A SOLUTION WITH A CONSTANT THICKNESS OF 10 MM WITHOUT OUTER JOINTS. THE MATTE FINISH ALLOWS A MORE EVEN DIFFUSION OF LIGHT, WHILE MASKING ANY DEPOSITS OF DUST ON THE SURFACE.

TECHNICAL SPECIFICATIONS

MALE FEMALE INTERLOCKING SYSTEM IN POLYCARBONATE, NON UV PROTECTED, 600/750 VARIABLE MODULE 10 mm THICK CRYSTAL AND OPAL COLOR, ALVEOLAR CELLS CLOSED WITH HEAT-WELDING.

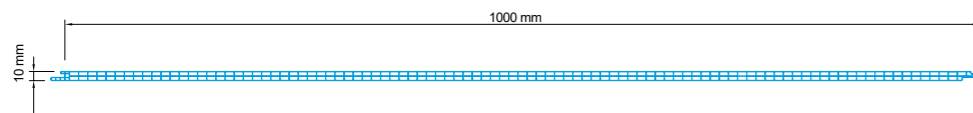

Maximum distance between supports: 1.60 m.

Thickness	10 mm
Structure	Multialveolar 3 walls
Width	1000 mm
Length	Cut to size
Color	Crystal / Opal
Light transmission	Crystal 78% / Opal 60%
Thermal transmittance	2,40 W/m ² K
Linear expansion	0,065 mm/m °C
Fire resistance certification EN 13501-1	B-s1,d0
Operating temperature	min - 40 °C / max +120 °C
Vicat	151°
Maximum distance between supports	1600 mm



ALVE - ROOF VELARIO 6 WALLS NO UV

20/25/30/40 mm

POLYCARBONATE INTERLOCKING SYSTEM: MALE-FEMALE JOINTS FOR A PERFECT FIT

ALVE-ROOF VELARIO 6-WALLS 20/25/30/40 mm IS RECOMMENDED FOR THE CONSTRUCTION OF FALSE CEILINGS, CURTAINS, INTERNAL DIVIDERS AND IN ALL THOSE SOLUTIONS NOT SUBJECTED TO THE DIRECT ACTION OF SUNLIGHT. PRACTICALITY AND COST-EFFECTIVENESS MAKE IT THE WINNING SOLUTION WHERE THE FOLLOWING IS REQUIRED:

- EXTRA-LIGHTWEIGHT
- HIGH IMPACT RESISTANCE
- HIGH LIGHT TRANSMISSION
- GOOD THERMAL INSULATION

THE SPECIAL INTERLOCKING SYSTEM FACILITATES INSTALLATION AND MAKES IT POSSIBLE TO IMPLEMENT A SOLUTION WITH A CONSTANT THICKNESS OF 20/25/30/40 mm. THE MATTE FINISH ALLOWS A MORE EVEN DIFFUSION OF LIGHT, WHILE MASKING ANY DEPOSITS OF DUST ON THE SURFACE.

TECHNICAL SPECIFICATIONS

ALVE-ROOF VELARIO 6-WALLS 20/25/30/40 mm COMPOSED OF: PANEL IN MULTIWALL POLYCARBONATE NON UV PROTECTED, CO-EXTRUDED ON THE OUTER SIDE, MULTIWALL STRUCTURE, COLOR ON REQUEST. DIMENSIONS: MODULE WIDTH 500 mm, LENGTH CUT TO SIZE.

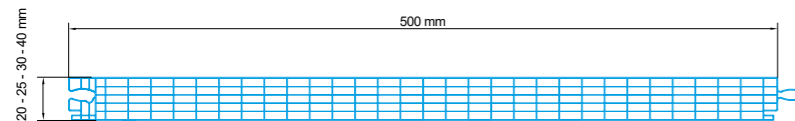

Thickness	20 mm	25 mm	30 mm	40 mm
Width	500 mm	500 mm	500 mm	500 mm
Length	On request	On request	On request	On request
Color	Crystal / Opal	Crystal / Opal	Crystal / Opal	Crystal / Opal
Light transmission	58% / 40%	55% / 38%	52% / 37%	50% / 36%
Thermal transmittance	1,60 W/m ² K	1,40 W/m ² K	1,30 W/m ² K	1,10 W/m ² K
Linear expansion	0,065 mm/m °C	0,065 mm/m °C	0,065 mm/m °C	0,065 mm/m °C
Vicat	146:-151° ISO 306	146:-151° ISO 306	146:-151° ISO 306	146:-151° ISO 306
Acoustic insulation	18dB	20dB	21dB	22dB
Fire resistance certification EN 13501-1	B-s1,d0	B-s1,d0	B-s1,d0	B-s1,d0
Operating temperature	min - 40 °C/ max +120 °C	min - 40 °C/ max +120 °C	min - 40 °C/ max +120 °C	min - 40 °C/ max +120 °C



ALVE ROOF COOP VELARIO 10 WALLS NO UV

16/20/25/32/40 mm

ALVE-ROOF COOP VELARIO 10 WALLS 16 / 20 / 25 / 30 / 40 mm IS RECOMMENDED FOR THE CONSTRUCTION OF FALSE CEILINGS, CURTAINS, INTERNAL DIVIDERS AND IN ALL THOSE SOLUTIONS NOT SUBJECTED TO THE DIRECT ACTION OF SUNLIGHT. PRACTICALITY AND COST-EFFECTIVENESS MAKE IT THE WINNING SOLUTION WHERE THE FOLLOWING IS REQUIRED:

- EXTRA-LIGHTWEIGHT
- HIGH IMPACT RESISTANCE
- HIGH LIGHT TRANSMISSION
- GOOD THERMAL INSULATION

ALVE ROOF COOP VELARIO CAN BE CURVED WITH A RADIUS OF 3300 mm O 6000 mm AND A MAXIMUM DEVELOPMENT OF 5000 mm

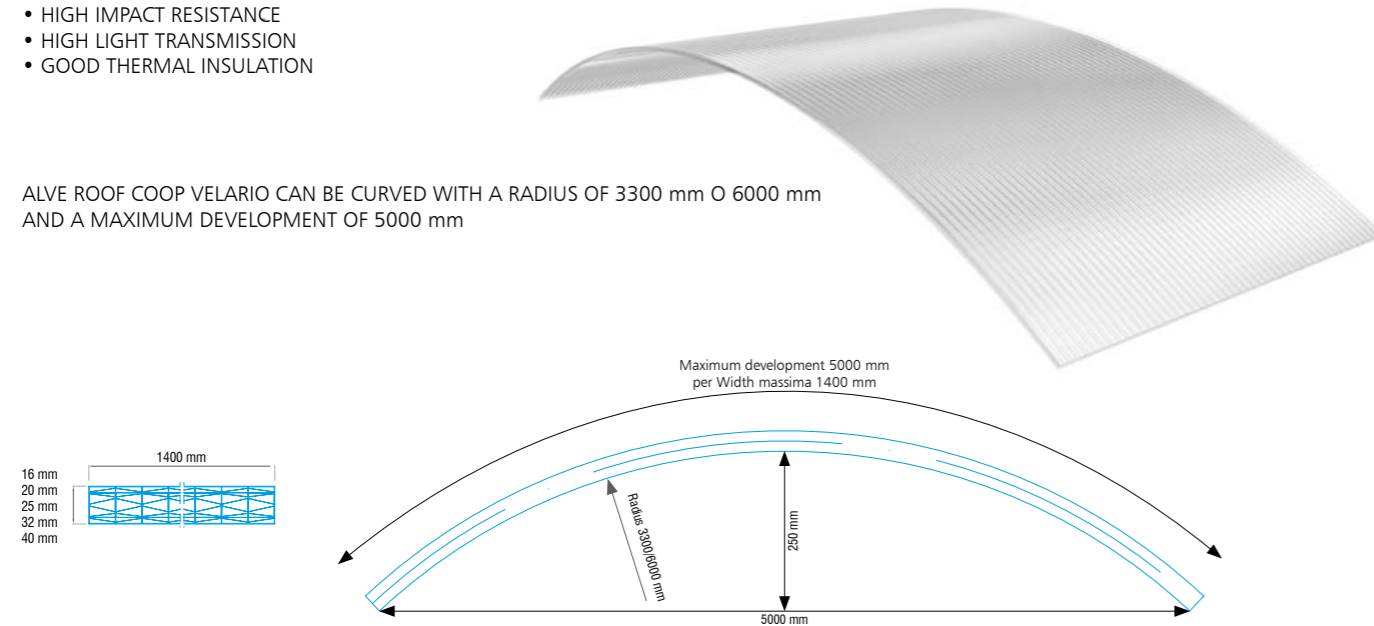

Thickness	16 mm	20 mm	25 mm	32 mm	40 mm
Width up to	1400 mm	1400 mm	1400 mm	1400 mm	1400 mm
Length	On request max 6000	On request max 6000	On request max 6000	On request max 6000	On request max 6000
Radius	3300 / 6000 mm (Longitudinal axis)	3300 / 6000 mm (Longitudinal axis)	3300 / 6000 mm (Longitudinal axis)	3300 / 6000 mm (Longitudinal axis)	3300 / 6000 mm (Longitudinal axis)
Deflection	250 mm	250 mm	250 mm	250 mm	250 mm
Color	Opal	Opal	Opal	Opal	Opal
Light transmission	45%	48%	34 %	31%	28%
Trasmissione solare	50%	50%	45%	34%	30%
Thermal transmittance	1,60 W/m ² K	1,60 W/m ² K	1,40 W/m ² K	1,30 W/m ² K	1,10 W/m ² K
Linear expansion	0,065 mm/m °C	0,065 mm/m °C	0,065 mm/m °C	0,065 mm/m °C	0,065 mm/m °C
Vicat	146:-151° ISO 306	146:-151° ISO 306	146:-151° ISO 306	146:-151° ISO 306	146:-151° ISO 306
Acoustic insulation	18dB	20dB	21dB	21dB	22dB
Fire resistance certification EN 13501-1	B-s1,d0	B-s1,d0	B-s1,d0	B-s1,d0	B-s1,d0
Operating temperature	min - 40 °C/ max +120 °C	min - 40 °C/ max +120 °C	min - 40 °C/ max +120 °C	min - 40 °C/ max +120 °C	min - 40 °C/ max +120 °C

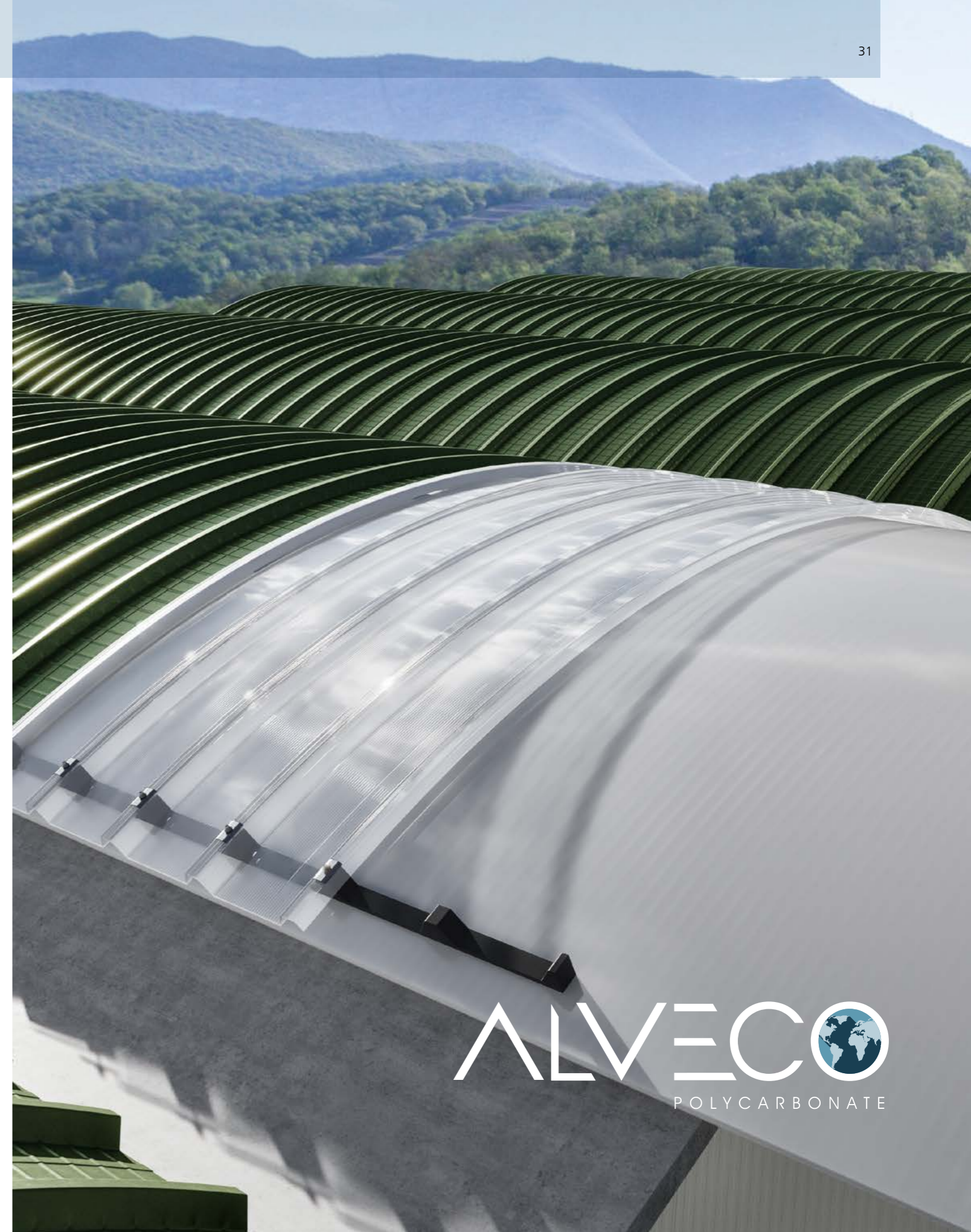

ALVE ROOF COOP 10 WALLS UV

16/20/25/32 mm

ALVE-ROOF COOP 10 WALLS IS SUITABLE FOR CREATING CURVED EXTERNAL SURFACES IN POLYCARBONATE. ITS PRACTICALITY AND AFFORDABILITY MAKE IT THE WINNING SOLUTION WHEREVER:

- EXTRA-LIGHTWEIGHT
- HIGH IMPACT RESISTANCE
- HIGH LIGHT TRANSMISSION
- GOOD THERMAL INSULATION

ALVE-ROOF COOP WITH 10 WALLS HAS A UV PROTECTION OBTAINED BY COEXTRUSION ON THE OUTER SIDE.

ALVE ROOF COOP VELARIO CAN BE CURVED WITH A RADIUS OF 930 mm AND A MAXIMUM DEVELOPMENT OF 1400 mm X 6000 mm

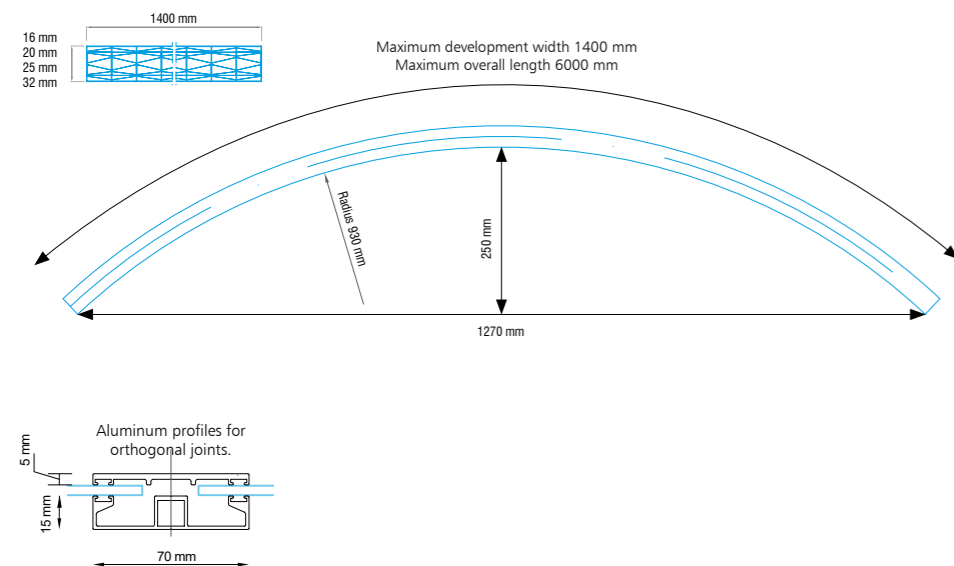

Thickness	16 mm	20 mm	25 mm	32 mm
Width fino a:	1400 mm	1400 mm	1400 mm	1400 mm
Maximum overall length	6000	6000	6000	6000
Radius	930 mm (Orthogonal axis)	930 mm (Orthogonal axis)	930 mm (Orthogonal axis)	930 mm (Orthogonal axis)
Deflection	250 mm	250 mm	250 mm	250 mm
Color	Opal	Opal	Opal	Opal
Light transmission	45%	58%	34 %	31%
Trasmisione solare	50%	50%	45%	34%
Thermal transmittance	1,60 W/m ² K	1,40 W/m ² K	1,30 W/m ² K	1,20 W/m ² K
Linear expansion	0,065 mm/m °C	0,065 mm/m °C	0,065 mm/m °C	0,065 mm/m °C
Vicat	146:-151° ISO 306	146:-151° ISO 306	146:-151° ISO 306	146:-151° ISO 306
Acoustic insulation	18dB	20dB	21dB	21dB
Fire resistance certification EN 13501-1	B-s1,d0	B-s1,d0	B-s1,d0	B-s1,d0
Operating temperature	min - 40 °C / max +120 °C	min - 40 °C / max +120 °C	min - 40 °C / max +120 °C	min - 40 °C / max +120 °C



ALVE - WALL 20-25-30 SECTION 6 WALLS UV

20/25/30 mm

MALE FEMALE INTERLOCKING SYSTEM IN MULTIWALL POLYCARBONATE

ALVE-WALL 20 / 25 / 30 SECTION 6 WALLS IS AN ALVEOLAR POLYCARBONATE SYSTEM, RECOMMENDED FOR THE CONSTRUCTION OF TRANSLUCENT WALLS AND VERTICAL INFILL PANELS. THE SYSTEM IS COMPOSED OF PANELS IN MULTIWALL POLYCARBONATE WITH MULTIWALL STRUCTURE, THICKNESS 20 / 25 / 30 mm, MODULE WIDTH 500 mm, UV PROTECTED AND CO-EXTRUDED ON THE OUTER SIDE.

TECHNICAL SPECIFICATIONS

ALVE-WALL 20 / 25 / 30 SECTION 6 WALLS COMPOSED OF: PANEL IN MULTIWALL POLYCARBONATE, UV PROTECTED, CO-EXTRUDED ON THE OUTER SIDE MULTIWALL STRUCTURE, COLOR ON REQUEST. DIMENSIONS: MODULE WIDTH 500 mm, LENGTH CUT TO SIZE.

- ANODIZED OR COLORED ALUMINUM PERIMETER PROFILES OR, ALTERNATIVELY, THERMALLY BROKEN PERIMETER PROFILES.
- OUTER GASKETS IN EPDM RUBBER.
- ALUMINUM PLATE FOR FASTENING THE PANELS (WHERE REQUIRED).

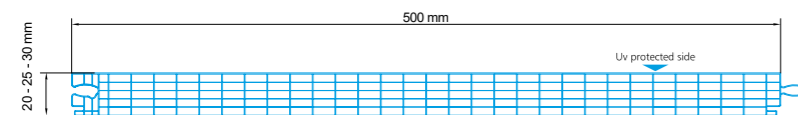

Thickness	20 mm	25 mm	30 mm
Width	500 mm	500 mm	500 mm
Length	On request	On request	On request
Color	Crystal / Opal	Crystal / Opal	Crystal / Opal
Light transmission	58% / 40%	55% / 38%	52% / 37%
Thermal transmittance	1,60 W/m ² K	1,40 W/m ² K	1,30 W/m ² K
Linear expansion	0,065 mm/m °C	0,065 mm/m °C	0,065 mm/m °C
Vicat	146:-151° ISO 306	146:-151° ISO 306	146:-151° ISO 306
Acoustic insulation	18dB	20dB	21dB
Fire resistance certification EN 13501-1	B-s1,d0	B-s1,d0	B-s1,d0
Operating temperature	min - 40 °C / max +120 °C	min - 40 °C / max +120 °C	min - 40 °C / max +120 °C
UV protection	Upper side	Upper side	Upper side

THICKNESS 20 mm

PERMISSIBLE LOADS ON 2 SUPPORTS

System resistance with evenly distributed load. The graph refers to a correct installation according to the Technical Manual.

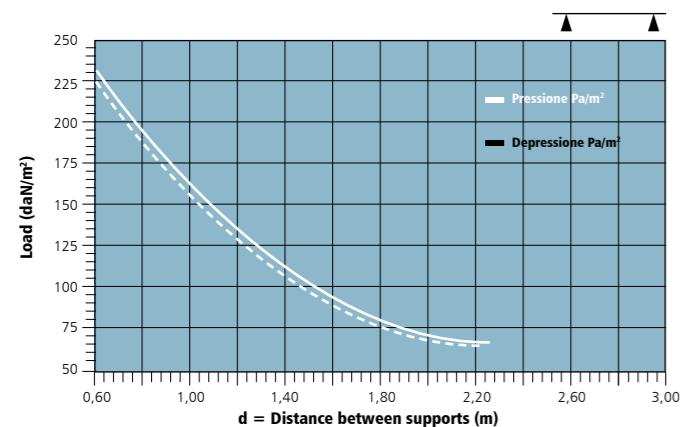

PERMISSIBLE LOADS ON MULTIPLE SUPPORTS

System resistance with evenly distributed load. The graph refers to a correct installation according to the Technical Manual.

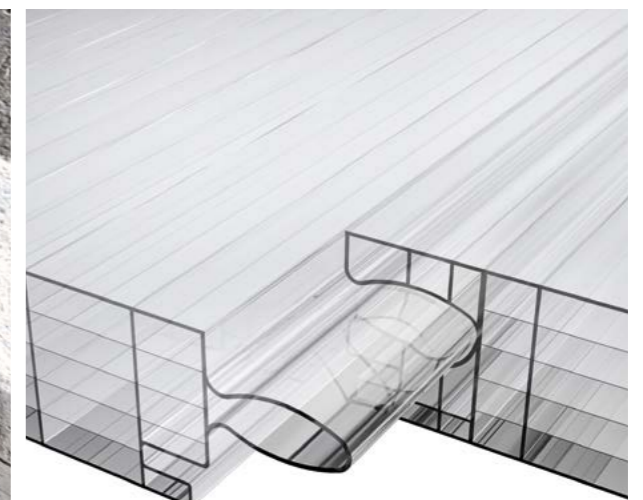
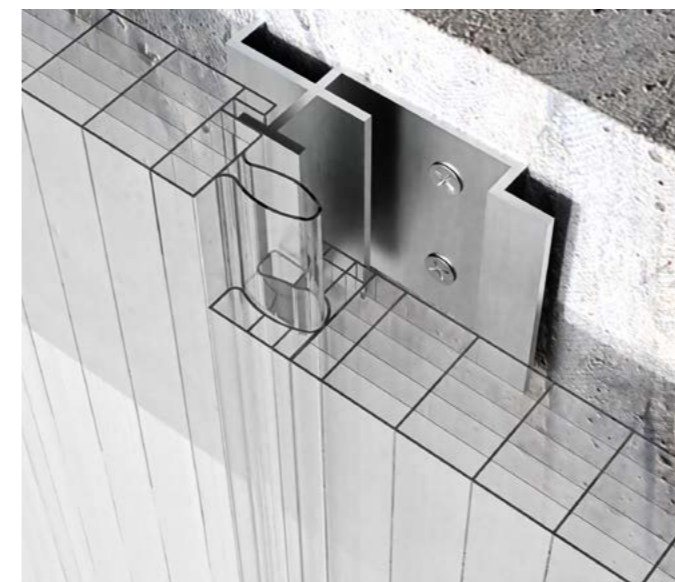
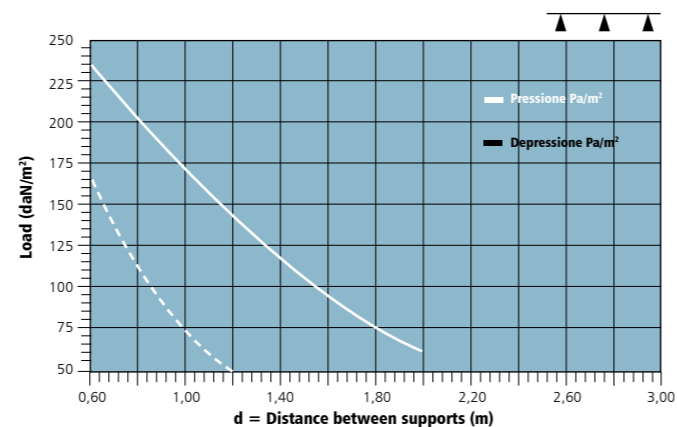

ALVE - WALL SECTION 6 WALLS UV SISTEMA FINESTRATURA

PROFILI NECESSARI PER LA REALIZZAZIONE DI SISTEMI IN PARETE PER I PANNELLI ALVE-WALL

INSTALLATION FACE TO THE WALL WITH DRIP (COLD PROFILES)

INSTALLATION FACE TO THE WALL WITHOUT DRIP (COLD PROFILES)

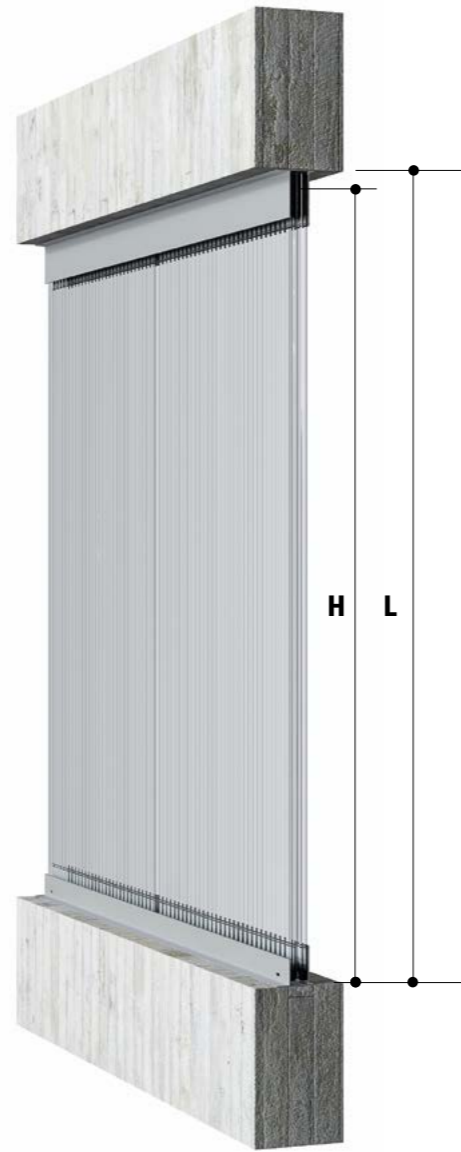
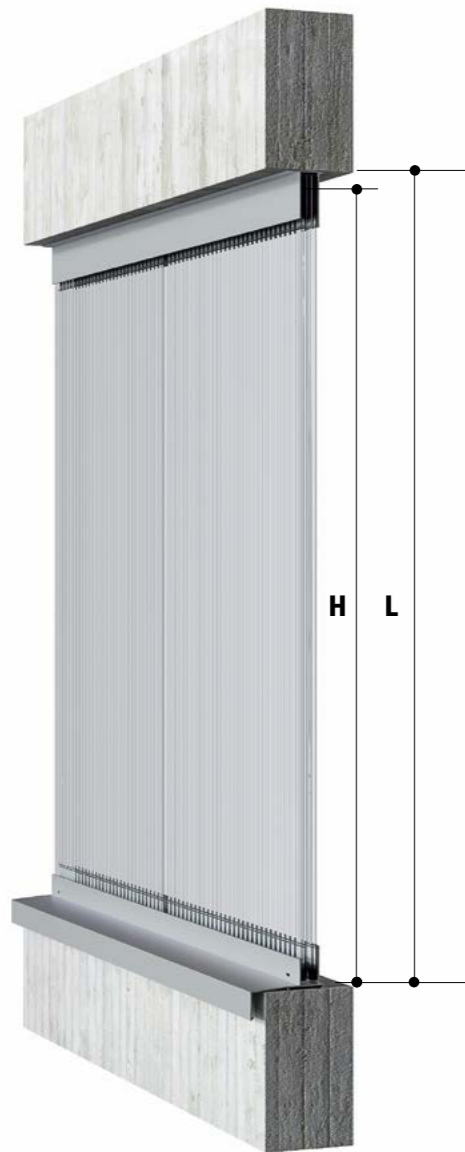

L= SPACE NET SPAN
H= PANEL HEIGHT
H= DELTA L -40mm

L= SPACE NET SPAN
H= PANEL HEIGHT
H= DELTA L -40mm



PLATE DETAIL OF INTERMEDIATE PLATFORM.



LOWER PROFILE DETAIL OF FASTENING, ALSO AVAILABLE WITH THERMALLY BROKEN



UPPER PROFILE DETAIL

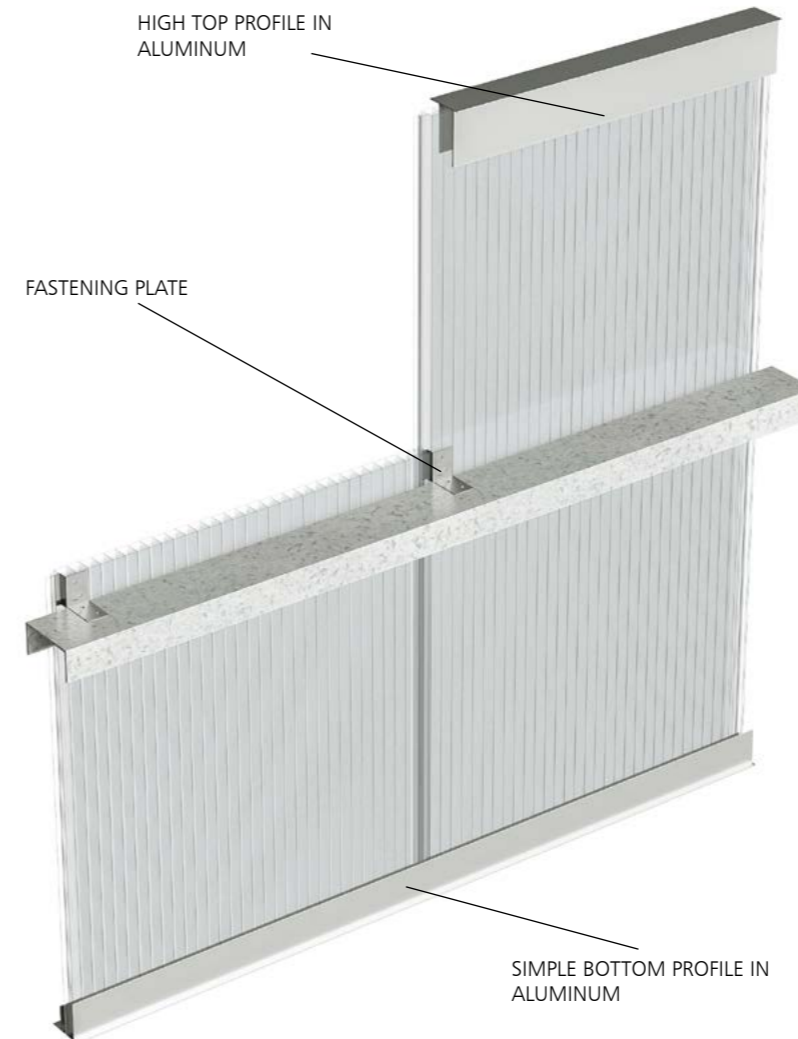

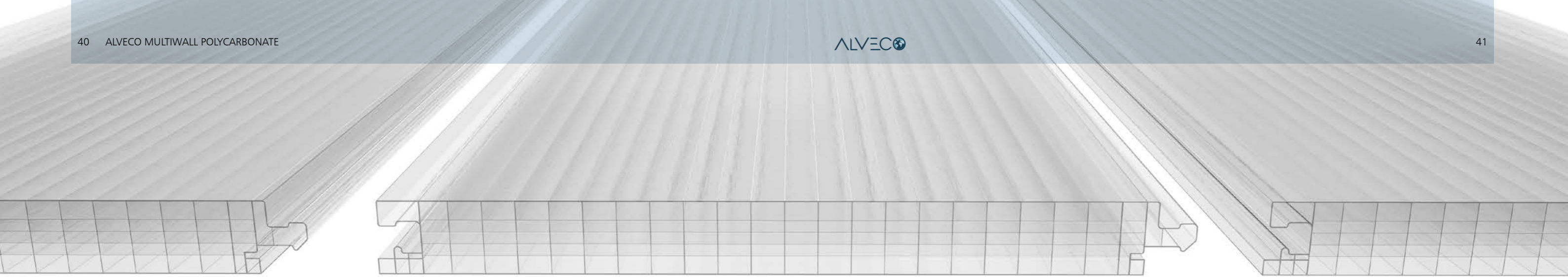

ALVE - WALL 40-50 SECTION 6 WALLS ^{UV}

40/50 mm

MALE FEMALE INTERLOCKING SYSTEM IN MULTIWALL POLYCARBONATE

ALVE - WALL 40-50 SECTION 6 WALLS, UV PROTECTED, IT IS AN INTERLOCKING MULTIWALL SHEET PANELS WITH A PROFILED TONGUE AND GROOVE CONNECTION RECCOMENDED FOR THE CONSTRUCTION OF TRANSLUCENT WALLS AND VERTICAL INFILL PANELS. THE SYSTEM IS COMPOSED OF PANELS IN MULTIWALL POLYCARBONATE WITH 6-WALLS STRUCTURE, THICKNESS 40 mm, MODULE WIDTH 500 mm, UV PROTECTED AND CO-EXTRUDED ON THE OUTER SIDE.

TECHNICAL SPECIFICATIONS

ALVE - WALL 40-50 SECTION 6 WALLS, UV PROTECTED, COMPOSED OF: PANEL IN MULTIWALL POLYCARBONATE, UV PROTECTED, CO-EXTRUDED ON THE OUTER SIDE 6-WALLS STRUCTURE, COLOR ON REQUEST. DIMENSIONS: MODULE WIDTH 500 mm, LENGTH CUT TO SIZE.

- ANODIZED OR COLORED ALUMINUM PERIMETER PROFILES OR, ALTERNATIVELY, THERMALLY BROKEN PERIMETER PROFILES.
- OUTER GASKETS IN EPDM RUBBER.
- ALUMINUM PLATE FOR FASTENING THE PANELS (WHERE REQUIRED)..

Thickness	40 mm	50 mm
Width	500 mm	500 mm
Length	On request	On request
Color	Crystal / Opal	Crystal / Opal
Light transmission	53% / 30%	51% / 30%
Thermal transmittance	1,10 W/m ² K	1,00 W/m ² K
Linear expansion	0,065 mm/m °C	0,065 mm/m °C
Vicat	150° C	150° C
Acoustic insulation	21dB	22dB
UV protection	Upper side	Upper side
Fire resistance certification EN 13501-1	B-s1,d0	B-s1,d0
Operating temperature	min - 40 °C/ max +120 °C	min - 40 °C/ max +120 °C

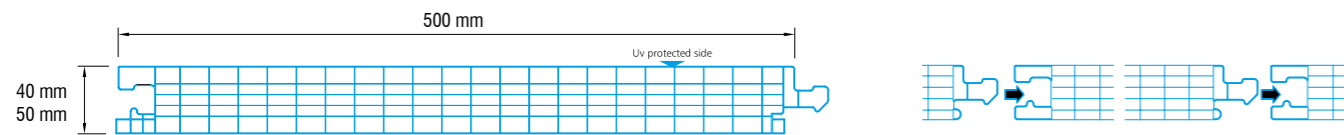

THICKNESS 40 mm

PERMISSIBLE LOADS ON 2 SUPPORTS

System resistance with evenly distributed load. The graph refers to a correct installation according to the Technical Manual.

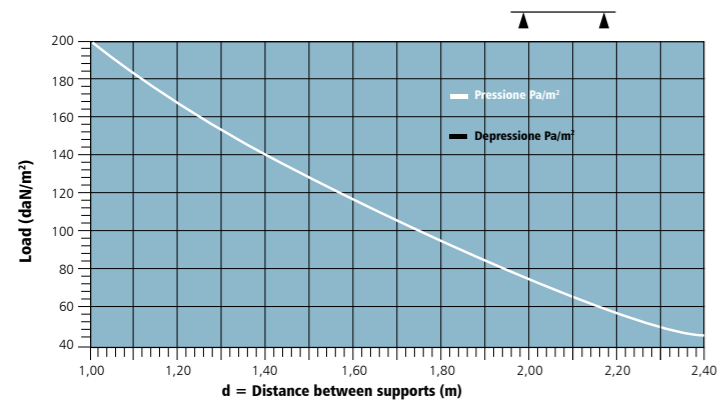

PERMISSIBLE LOADS ON MULTIPLE SUPPORTS

System resistance with evenly distributed load. The graph refers to a correct installation according to the Technical Manual.

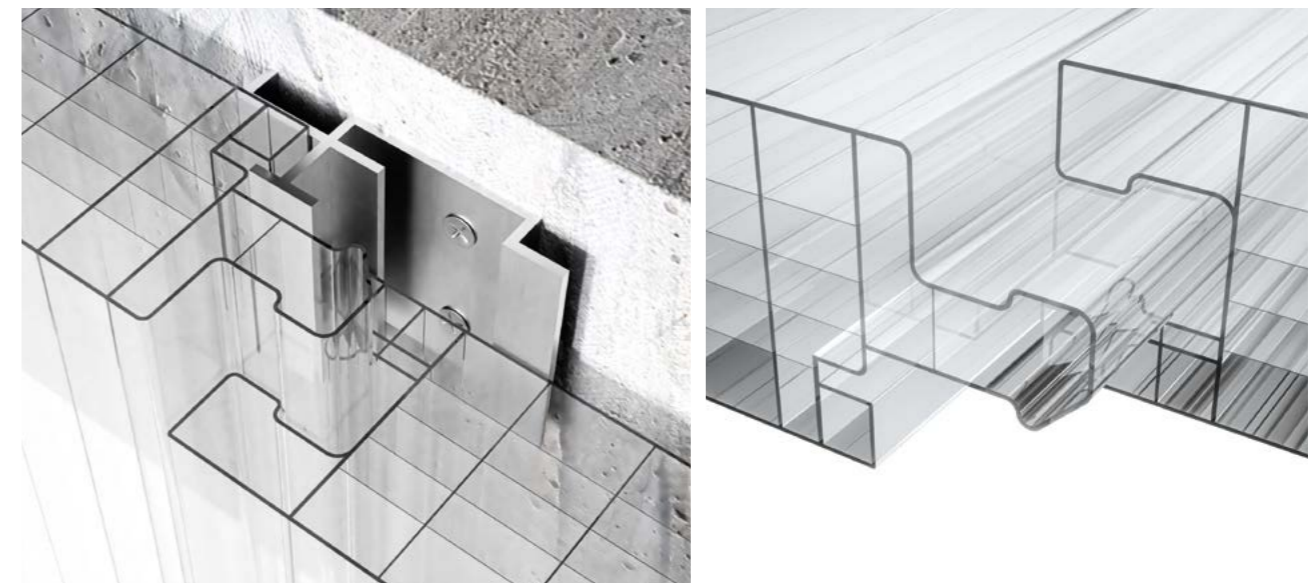
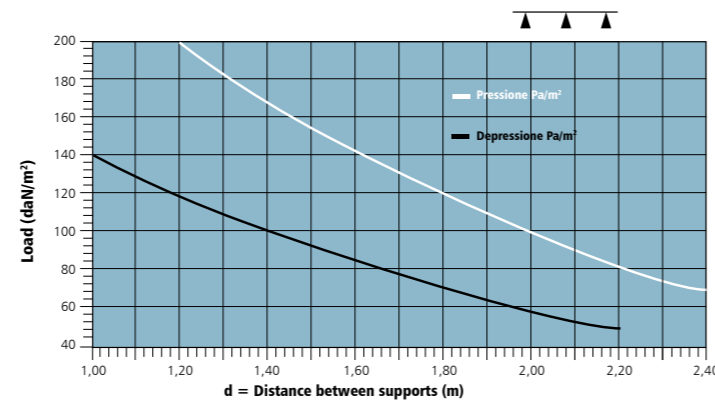

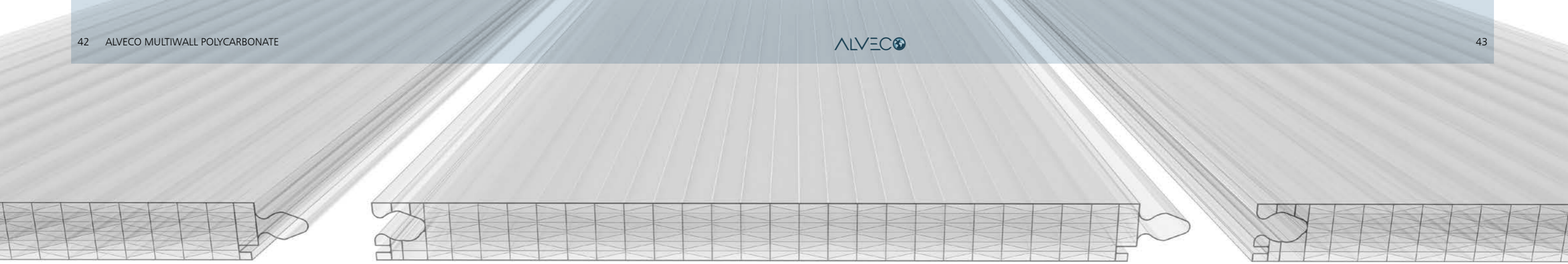

ALVE - WALL SECTION 13 WALLS UV

40/50/60 mm

MALE FEMALE INTERLOCKING SYSTEM IN MULTIWALL POLYCARBONATE

ALVE-WALL 13 WALLS 40 / 50 / 60 mm, UV PROTECTED, IT IS AN INTERLOCKING MULTIWALL SHEET PANELS WITH A PROFILED TONGUE AND GROOVE CONNECTION RECOMMENDED FOR THE CONSTRUCTION OF TRANSLUCENT WALLS AND VERTICAL INFILL PANELS. THE SYSTEM IS COMPOSED OF PANELS IN MULTIWALL POLYCARBONATE WITH 13 WALLS DIAGONAL STRUCTURE, THICKNESS 40 mm, MODULE WIDTH 500 mm, UV PROTECTED AND CO-EXTRUDED ON THE OUTER SIDE.

TECHNICAL SPECIFICATIONS

ALVE-WALL 13 WALLS 40 / 50 / 60 mm COMPOSED OF: PANEL IN MULTIWALL POLYCARBONATE, UV PROTECTED, CO-EXTRUDED ON THE OUTER SIDE, 13-WALLS STRUCTURE, COLOR ON REQUEST.

DIMENSIONS: MODULE WIDTH 500 mm, LENGTH CUT TO SIZE.

- ANODIZED OR COLORED ALUMINUM PERIMETER PROFILES OR, ALTERNATIVELY, THERMALLY BROKEN PERIMETER PROFILES.
- OUTER GASKETS IN EPDM RUBBER.
- ALUMINUM PLATE FOR FASTENING THE PANELS (WHERE REQUIRED).

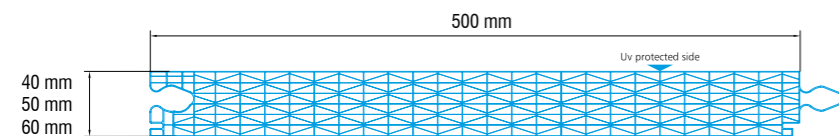

PERMISSIBLE LOADS ON 2 SUPPORTS

System resistance with evenly distributed load. The graph refers to a correct installation according to the Technical Manual.

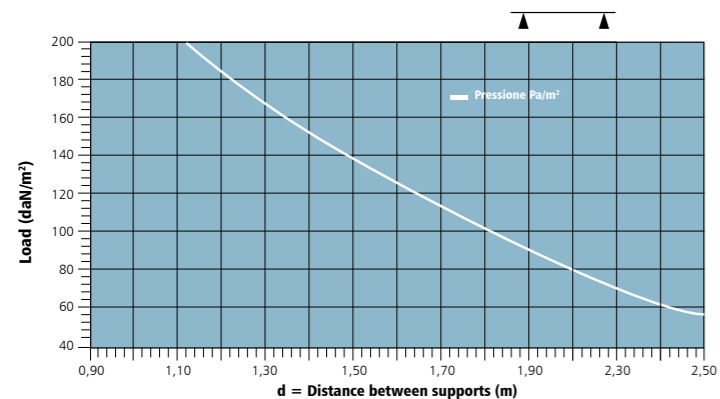

PERMISSIBLE LOADS ON MULTIPLE SUPPORTS

System resistance with evenly distributed load. The graph refers to a correct installation according to the Technical Manual.

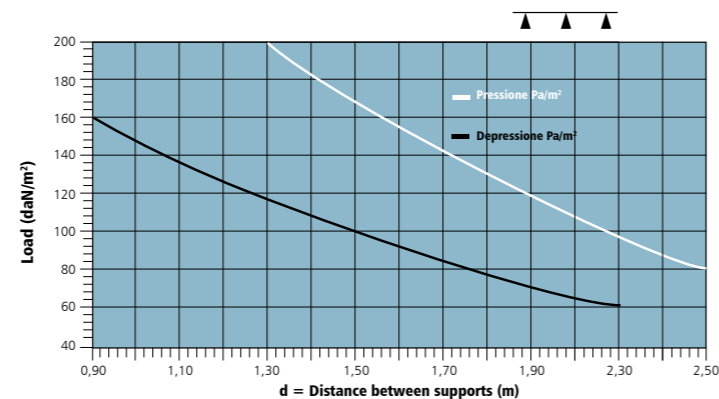

Thickness	40 mm	50 mm	60 mm
Width	500 mm	500 mm	500 mm
Length	On request	On request	On request
Color	Crystal / Opal	Crystal / Opal	Crystal / Opal
Light transmission	40% / 22%	46% / 34%	38% / 22%
Thermal transmittance	0,93 W/m² K	0,82 W/m² K	0,74 W/m² K
Linear expansion	0,065 mm/m °C	0,065 mm/m °C	0,065 mm/m °C
Vicat	150° C	150° C	150° C
Acoustic insulation	21dB	22dB	23dB
Fire resistance certification EN 13501-1	B-s1,d0	B-s1,d0	B-s1,d0
Operating temperature	min - 40 °C / max +120 °C	min - 40 °C / max +120 °C	min - 40 °C / max +120 °C
UV protection	Upper side	Upper side	Upper side



ALVE - WALL DOUBLE WALL SYSTEM

DOUBLE PANEL PROFILES ARE USED FOR BUILDING DOUBLE-WALLED FRAME ELEMENTS

THE DOUBLE WALL SYSTEM IS RECOMMENDED FOR A CLEAR INTERNAL AND EXTERNAL FAÇADE, THAT IS SUITABLE FOR CREATING TRANSLUCENT WALLS. THE SYSTEM IS BASED ON A DOUBLE POLYCARBONATE FAÇADE WITH ACCESSORIES.

ALVE-WALL SECTION 13 WALLS

Thickness	Thermal transmittance
Section 40+40 mm	0,48 W/m ² K
Section 50+50 mm	0,40 W/m ² K
Section 60+60 mm	0,36 W/m ² K

ALVE-WALL SECTION 6 WALLS

Thickness	Thermal transmittance
Section 40+40 mm	0,56 W/m ² K
Section 50+50 mm	0,49 W/m ² K

TECHNICAL SPECIFICATIONS

ALVE-WALL COMPOSED OF: PANEL IN MULTIWALL POLYCARBONATE, UV PROTECTED, CO-EXTRUDED ON THE OUTER SIDE -WALL STRUCTURE, COLOR ON REQUEST. DIMENSIONS: MODULE WIDTH 500 mm, LENGTH CUT TO SIZE.

- ANODIZED OR COLORED ALUMINUM PERIMETER PROFILES OR, ALTERNATIVELY, THERMALLY BROKEN PERIMETER PROFILES.
- OUTER GASKETS IN EPDM RUBBER.
- ALUMINUM PLATE FOR FASTENING THE PANELS (WHERE REQUIRED).

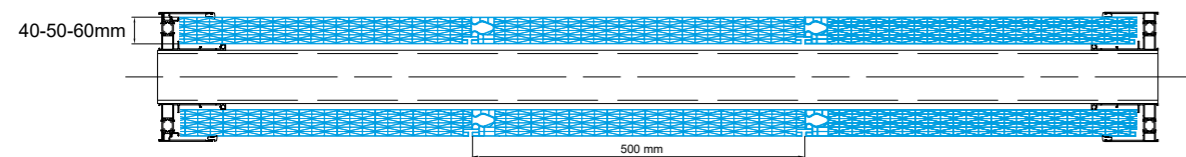
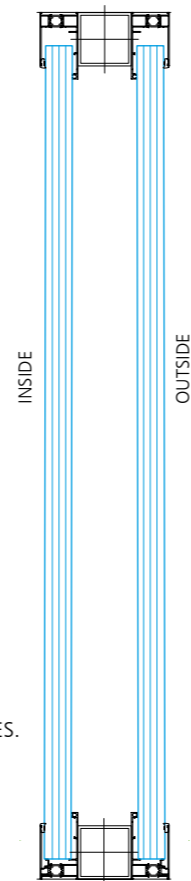

ALVE - WALL SECTION 6 WALLS_{UV} ALVE - WALL SECTION 13 WALLS_{UV} WINDOW SYSTEM

PROFILES NEEDED FOR THE CONSTRUCTION OF WALL SYSTEMS FOR ALVE-WALL PANELS

INSTALLATION FACE TO THE WALL WITH PLATFORM (COLD PROFILES)

INSTALLATION FACE TO THE WALL WITHOUT PLATFORM (COLD PROFILES)

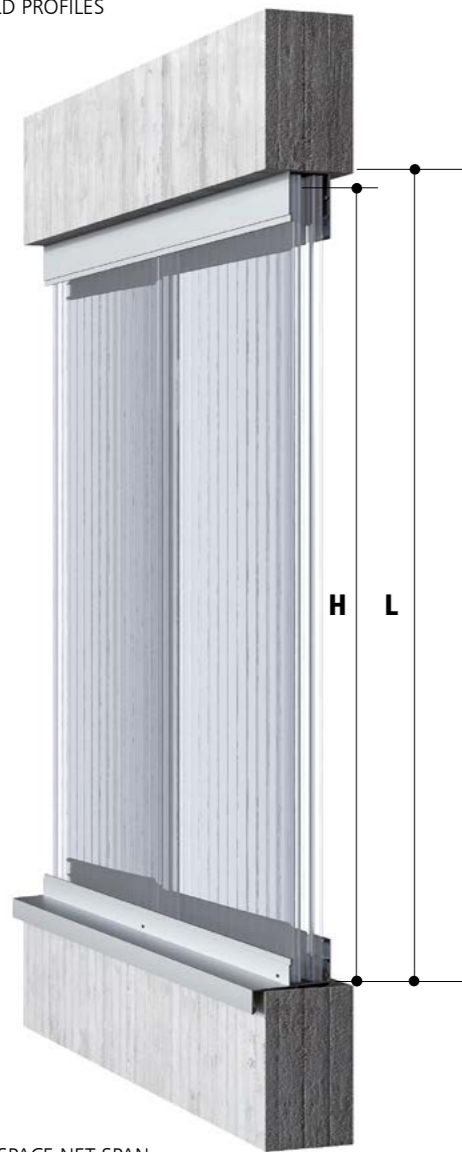

L= SPACE NET SPAN
H= PANEL HEIGHT
H= DELTA L-35mm cold profiles

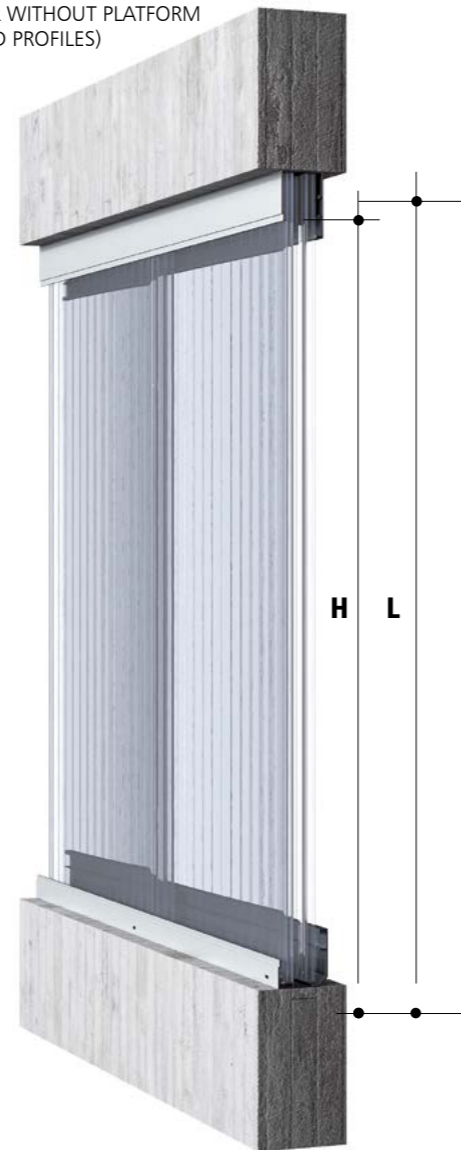

L= SPACE NET SPAN
H= PANEL HEIGHT
H= DELTA L-35mm cold profiles

L= LUCE NETTA DEL VANO
H= ALTEZZA PANNELLO
H= DELTA 68-80mm thermal break



DETAIL OF THE PLATFORM LOWER PROFILE, AVAILABLE EVEN WITH THERMALLY BROKEN



DETAIL OF THE UPPER PROFILE

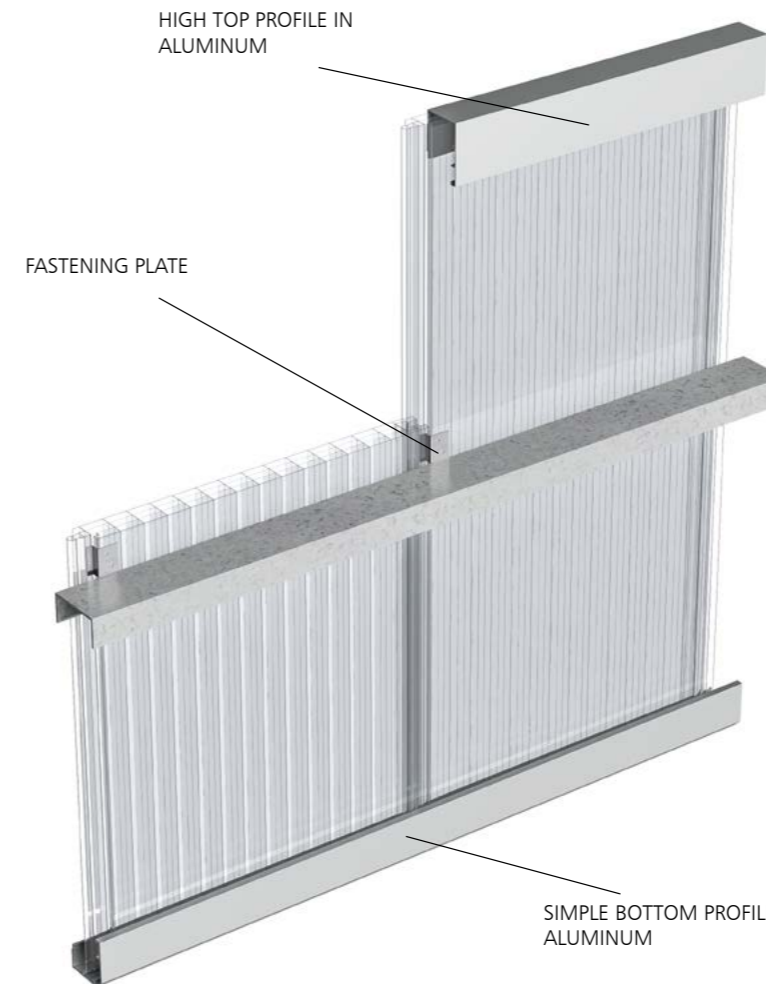

HIGH TOP PROFILE IN ALUMINUM

FASTENING PLATE

SIMPLE BOTTOM PROFILE IN ALUMINUM



ALVE - WALL OPENING SYSTEM

PROFILES NEEDED FOR THE CONSTRUCTION OF OPENINGS TO BE INCLUDED IN THE ALVE-WALL SYSTEM

THE ALVE-WALL SYSTEM CAN BE EQUIPPED WITH AN OPENING TO ALLOW PERFECT VENTILATION OF THE BUILDING. THE OPENING SYSTEM IS COMPOSED OF LOWER AND UPPER ALUMINUM PROFILES, EQUIPPED WITH RUBBER GASKETS FOR THE FULL CLOSURE, AND UPPER ANODIZED ALUMINUM HINGES. THE OPENING CAN BE MANUAL OR THROUGH AN ELECTRIC ACTUATOR. AVAILABLE EVEN WITH THERMALLY BROKEN.



STANDARD WINDOW WIDTH OUTER FRAME (L/MM)

Pannel	Qty. of panels		
	2	3	4
ALVE - WALL 13 walls UV	1.230 mm	1.730 mm	2.230 mm
ALVE - WALL 13 walls UV (with thermal break)	1.250 mm	1.750 mm	2.250 mm
ALVE - WALL 6 walls UV	1.180 mm	1.670 mm	2.170 mm

ALUMINUM PROFILES WITH THERMALLY BROKEN

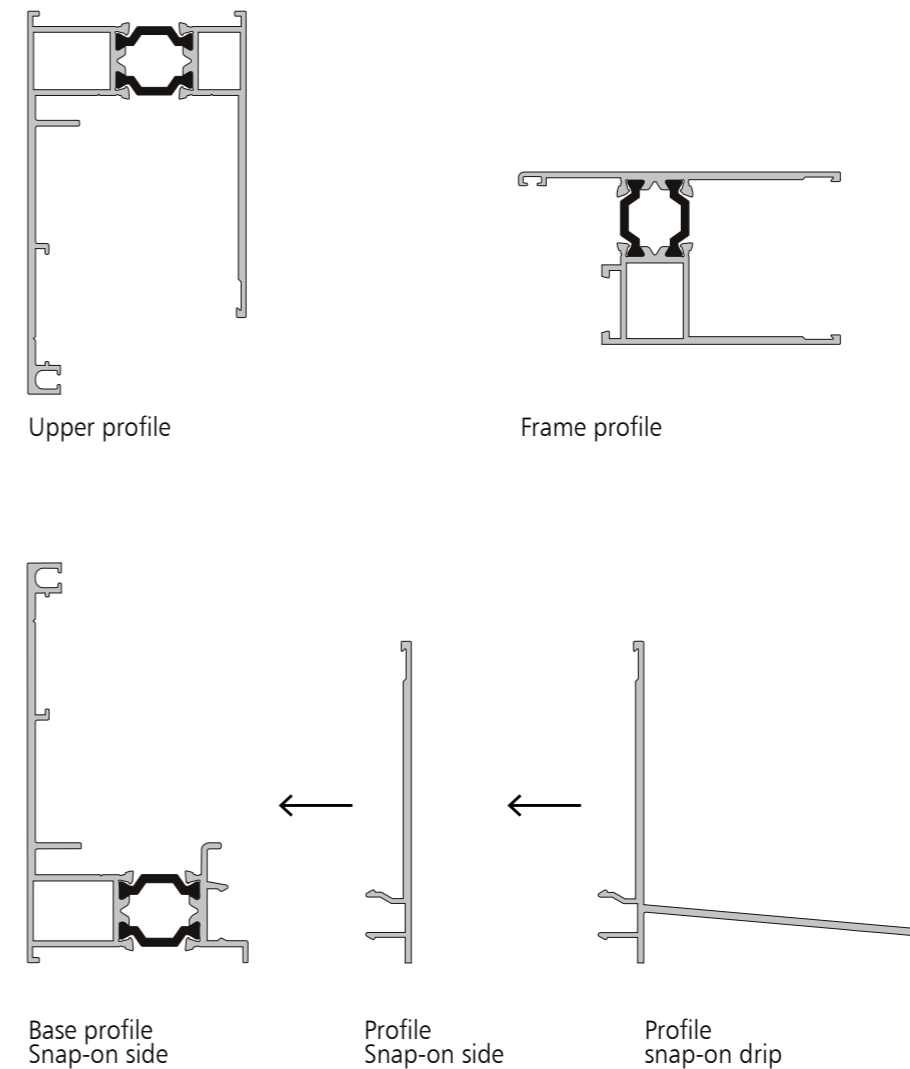

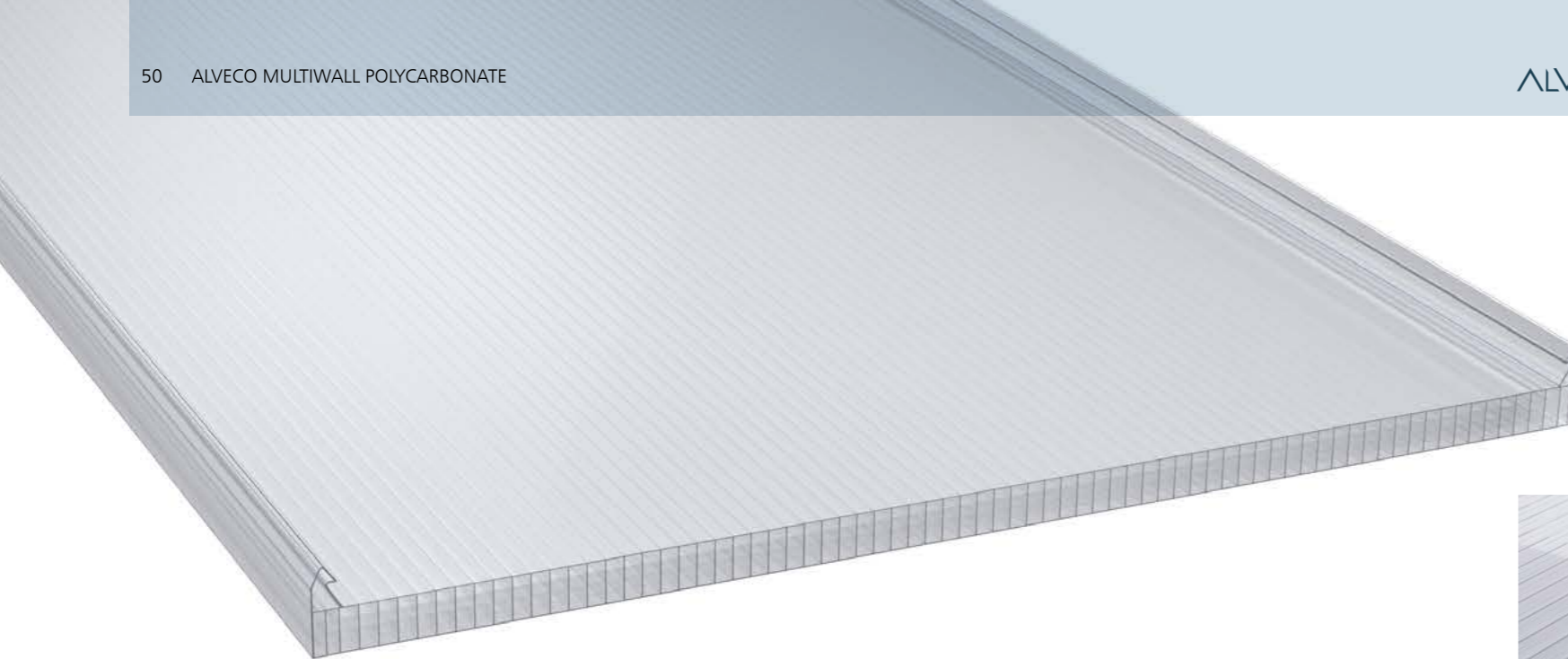

ALVE - WALL DUAL SYSTEM 600

10/16/20 mm
CONNECTING JOINT SYSTEM

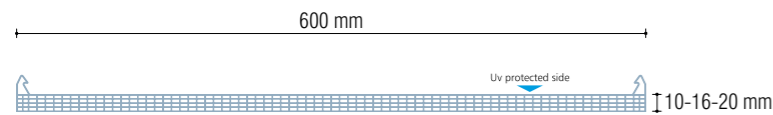

ALVE-WALL DUAL SYSTEM 600 10 / 16 / 20 mm IS AN ALVEOLAR POLYCARBONATE SYSTEM, RECOMMENDED FOR THE CONSTRUCTION OF TRANSLUCENT ROOFS AND COVERINGS AND VERTICAL INFILL PANELS. THE SYSTEM IS COMPOSED OF PANELS IN ALVEOLAR POLYCARBONATE WITH 5-WALLS DIAGONAL STRUCTURE, 10 mm THICK, 16 mm THICK, 20 mm THICK, MODULE WIDTH 600 mm, UV PROTECTED AND CO-EXTRUDED ON THE OUTER SIDE.

TECHNICAL SPECIFICATIONS

ALVE-WALL DUAL SYSTEM 600 10 / 16 / 20 mm IS COMPOSED OF:
 PANEL IN MULTIWALL POLYCARBONATE UV PROTECTED, CO-EXTRUDED ON TWO SIDES, 5-WALLS DIAGONAL STRUCTURE, COLOR ON REQUEST.
 DIMENSIONS: MODULE WIDTH 600 MM, LENGTH CUT TO SIZE.

- JOINING PROFILE IN POLYCARBONATE.
- ALUMINUM PLATE FOR PANEL FASTENING
- ALUMINUM / POLYCARBONATE SHUTTER FOR CLOSING THE ALVEOLI OR THROUGH HEAT-WELDING.

Thickness	10 mm	16 mm	20 mm
Width	600 mm	600 mm	600 mm
Length	On request	On request	On request
Color	Crystal / Opal	Crystal / Opal	Crystal / Opal
Light transmission	Crystal 65% Opal 40%	Crystal 65% Opal 40%	Crystal 65% Opal 40%
Thermal transmittance	2,50 W/m ² K	1,90 W/m ² K	1,70 W/m ² K
Linear expansion	0,065 mm/m °C	0,065 mm/m °C	0,065 mm/m °C
Fire resistance certification EN 13501-1	B-s1,d0	B-s1,d0	B-s1,d0
Operating temperature	min -30 °C / max +120 °C	min -30 °C / max +120 °C	min -30 °C / max +120 °C



JOINT COVER IN POLYCARBONATE



CONNECTOR IN ALUMINUM

THICKNESS 10/16 mm PERMISSIBLE LOADS ON ON 2 SUPPORTS

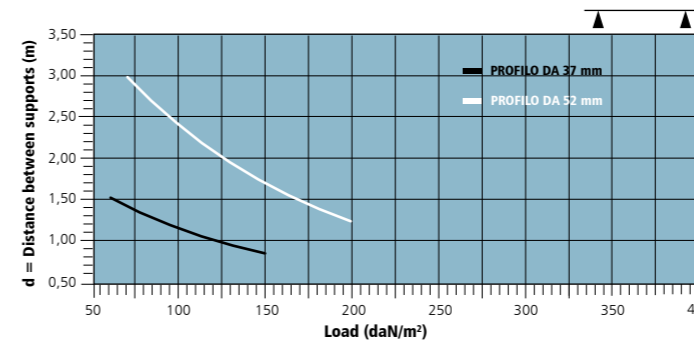

THICKNESS 20 mm PERMISSIBLE LOADS ON ON 2 SUPPORTS

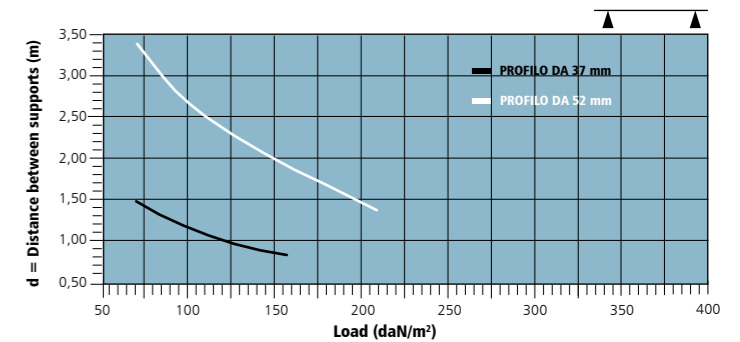

THICKNESS 10/16 mm PERMISSIBLE LOADS ON MULTIPLE SUPPORTS

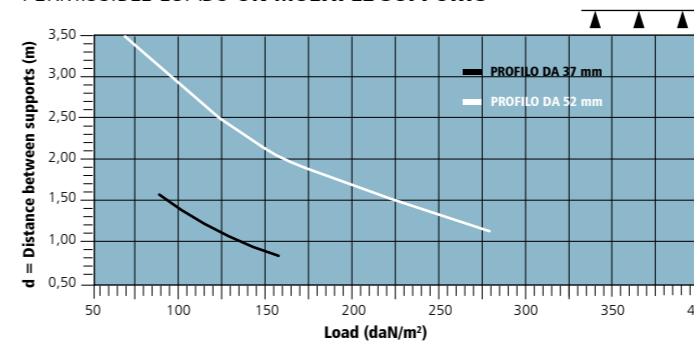

THICKNESS 20 mm PERMISSIBLE LOADS ON MULTIPLE SUPPORTS

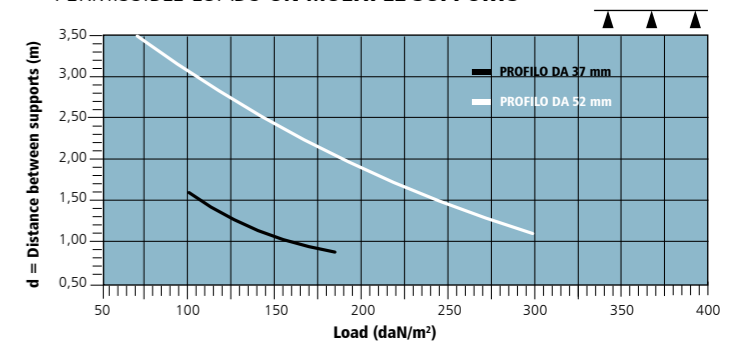

System resistance with evenly distributed load. The graph refers to a correct installation according to the Technical Manual.

System resistance with evenly distributed load. The graph refers to a correct installation according to the Technical Manual.

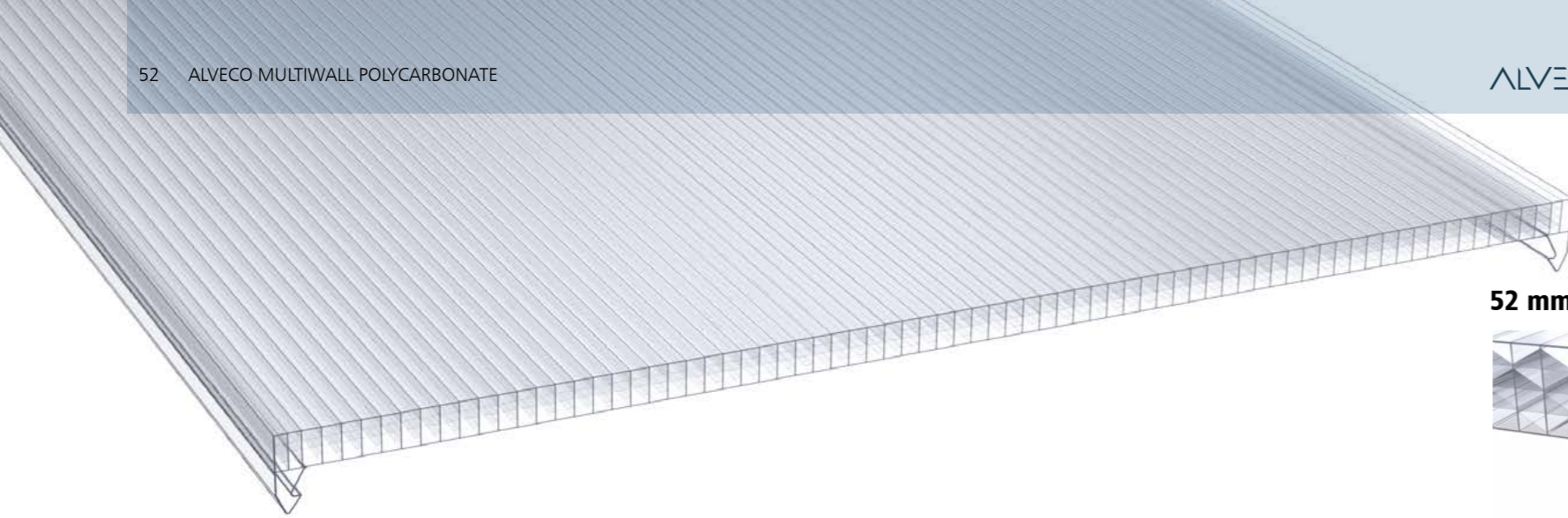

ALVE - ROOF DUAL SYSTEM 600

10/16/20 mm
CONNECTING JOINT SYSTEM

ALVE-ROOF DUAL SYSTEM 600 10 / 16 / 20 mm IS AN ALVEOLAR POLYCARBONATE SYSTEM, RECOMMENDED FOR THE CONSTRUCTION OF TRANSLUCENT ROOFS AND COVERINGS AND VERTICAL INFILL PANELS. THE SYSTEM IS COMPOSED OF PANELS IN ALVEOLAR POLYCARBONATE WITH 5-WALLS DIAGONAL STRUCTURE, 10 mm THICK, 16 mm THICK, 20 mm THICK, MODULE WIDTH 600 mm, UV PROTECTED AND CO-EXTRUDED ON THE OUTER SIDE.

TECHNICAL SPECIFICATIONS

ALVE-ROOF DUAL SYSTEM 600 10 / 16 / 20 mm IS COMPOSED OF:
PANEL IN MULTIWALL POLYCARBONATE UV PROTECTED, CO-EXTRUDED ON TWO SIDES, 5-WALLS DIAGONAL STRUCTURE, COLOR ON REQUEST.
DIMENSIONS: MODULE WIDTH 600 mm, LENGTH CUT TO SIZE.

- JOINING PROFILE IN POLYCARBONATE.
- ALUMINUM PLATE FOR PANEL FASTENING
- ALUMINUM / POLYCARBONATE SHUTTER FOR CLOSING THE ALVEOLI OR THROUGH HEAT-WELDING.

FOR CURVED ROOFS ALVECO DESIGNED AN ALUMINUM SYSTEM THAT GUARANTEES TIGHTNESS AND CAPACITY
SPECIAL JOINTS AND SUPPORTS GUARANTEE ELASTICITY AND VERSATILITY OF INSTALLATION.
MINIMUM CURVATURE RADIUS 2 METERS/THICKNESS 10 mm, CURVATURE RADIUS 4 METERS/THICKNESS 16/20 mm.

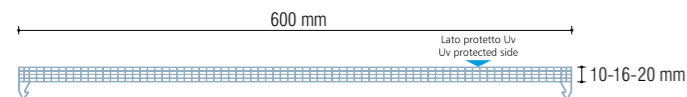

Thickness	10 mm	16 mm	20 mm
Width	600 mm	600 mm	600 mm
Length	On request	On request	On request
Color	Crystal / Opal	Crystal / Opal	Crystal / Opal
Light transmission	Crystal 65% Opal 40%	Crystal 65% Opal 40%	Crystal 65% Opal 40%
Thermal transmittance	2,50 W/m ² K	1,90 W/m ² K	1,70 W/m ² K
Linear expansion	0,065 mm/m °C	0,065 mm/m °C	0,065 mm/m °C
Fire resistance certification EN 13501-1	B-s1,d0	B-s1,d0	B-s1,d0
Operating temperature	min -30 °C / max +120 °C	min -30 °C / max +120 °C	min -30 °C / max +120 °C

52 mm PROFILE

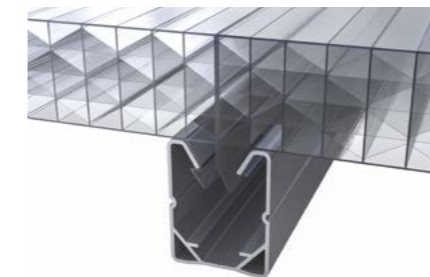

THICKNESS 10/16 mm
PERMISSIBLE LOADS ON 2 SUPPORTS

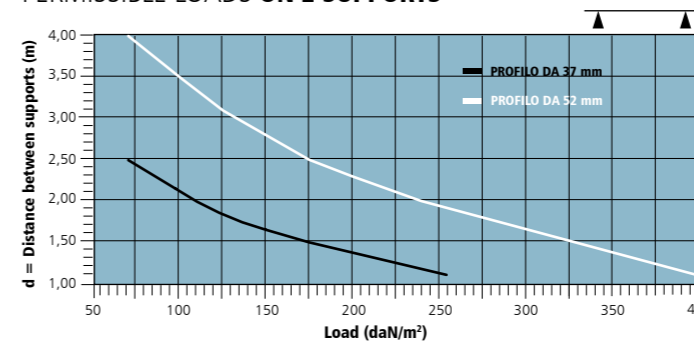

THICKNESS 10/16 mm
PERMISSIBLE LOADS ON MULTIPLE SUPPORTS

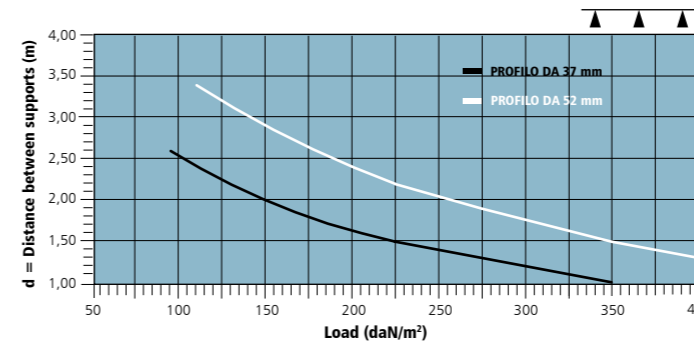

THICKNESS 10/16 mm
PERMISSIBLE LOADS ON 2 SUPPORTS r. 4000mm

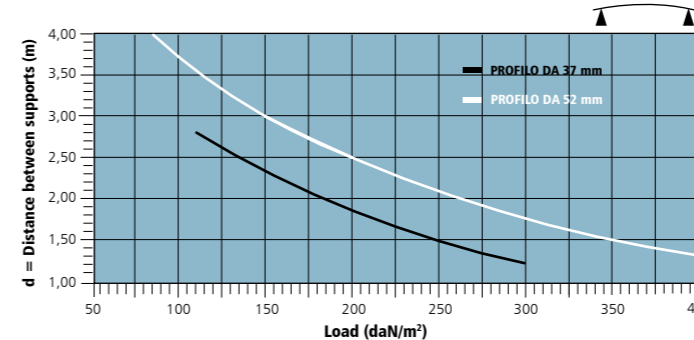

37 mm PROFILE

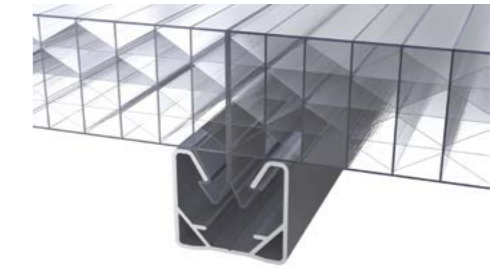

THICKNESS 20 mm
PERMISSIBLE LOADS ON 2 SUPPORTS

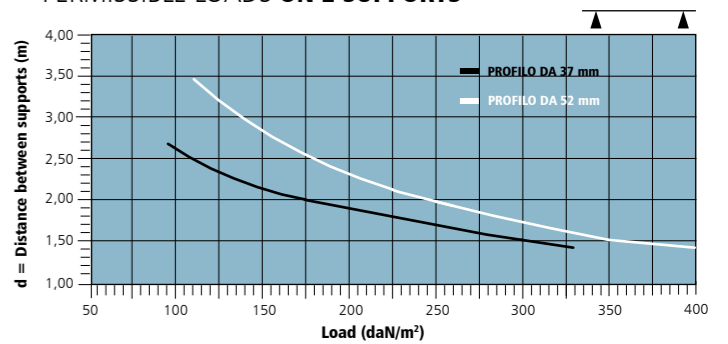

THICKNESS 20 mm
PERMISSIBLE LOADS ON MULTIPLE SUPPORTS

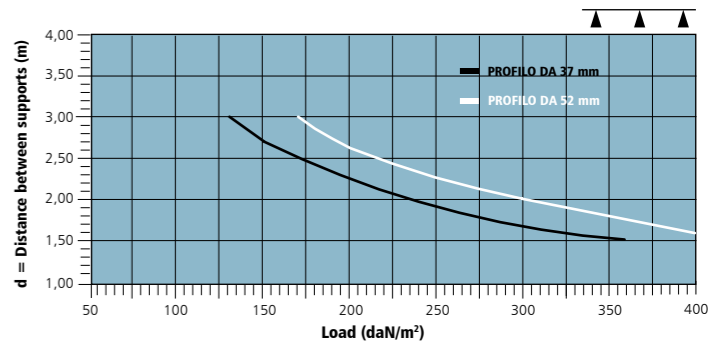

THICKNESS 20 mm
PERMISSIBLE LOADS ON 2 SUPPORTS r. 4000mm

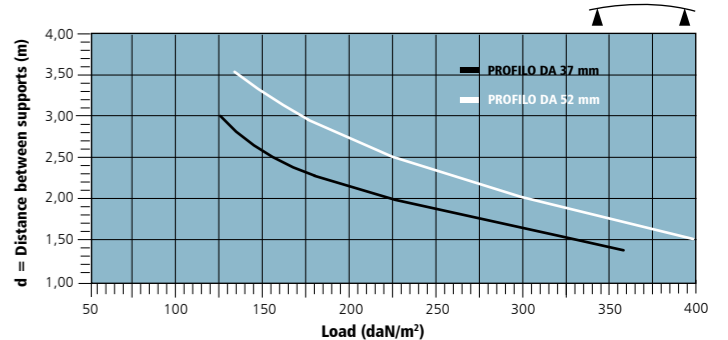

System resistance with evenly distributed load. The graph refers to a correct installation according to the Technical Manual.



ALVECO 
POLYCARBONATE

CONNECTOR IN ALUMINUM

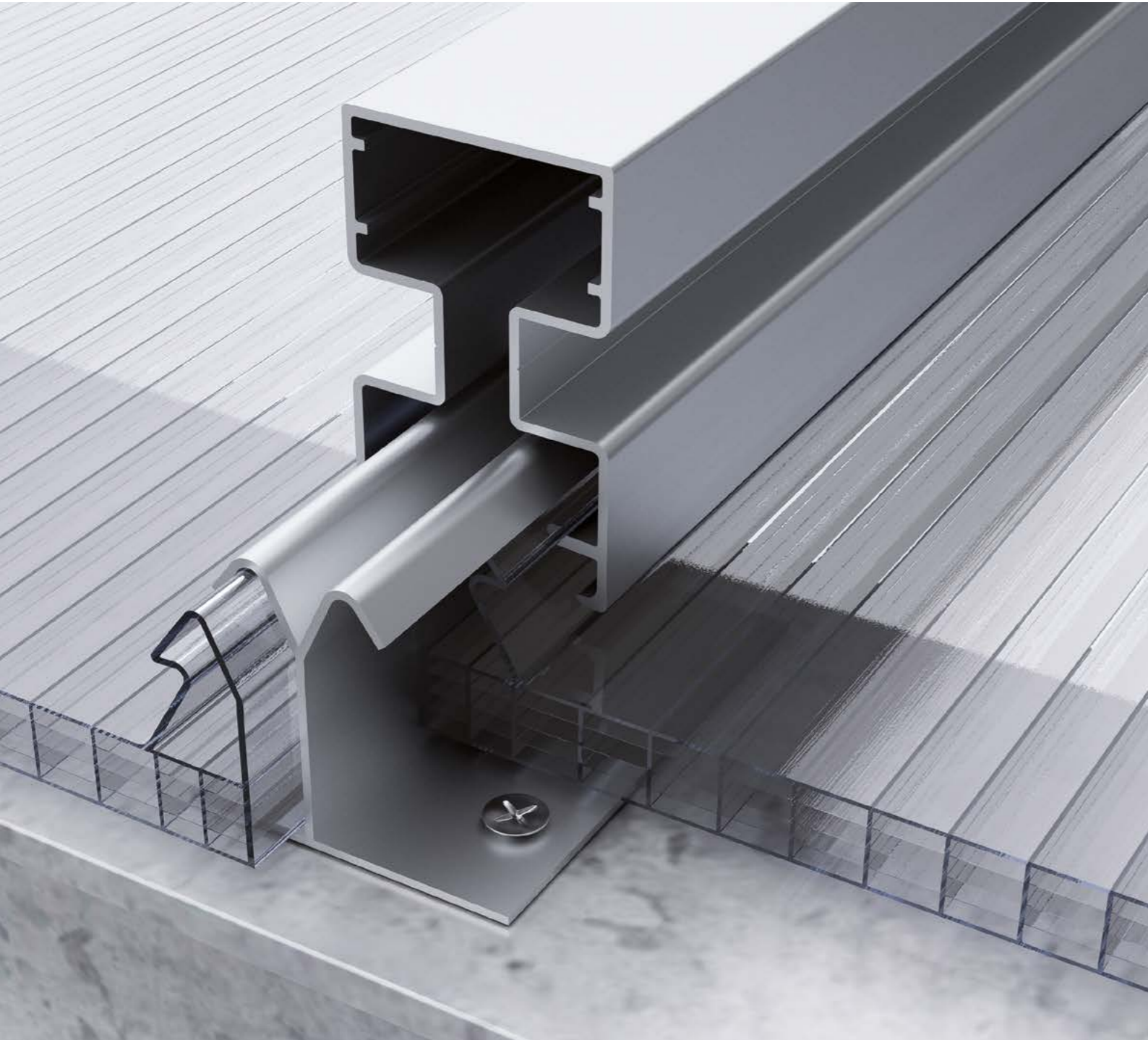

JOINT COVER IN POLYCARBONATE



WALL SYSTEM END

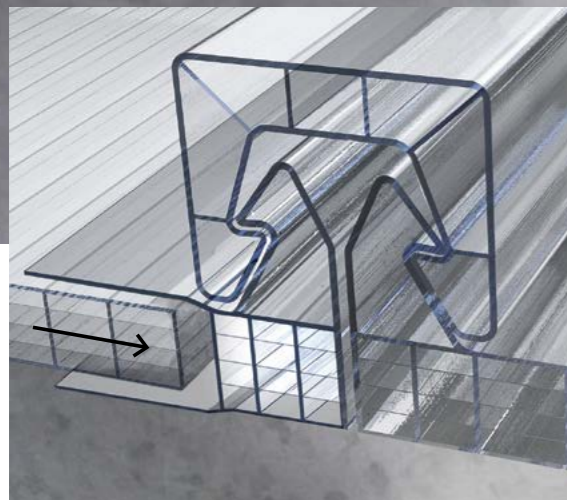
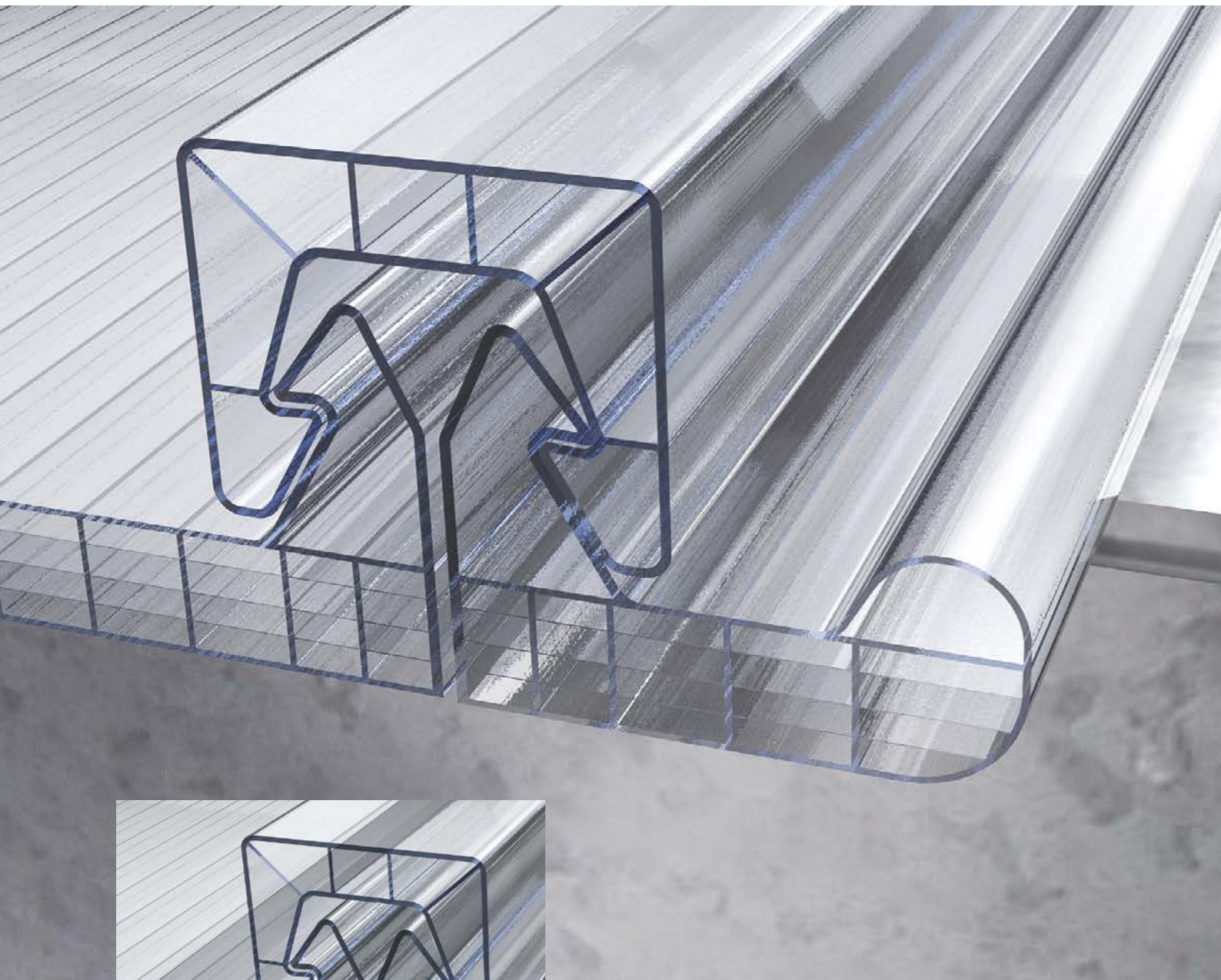

DETAIL PC CONNECTOR

COMPONENTS OF WALL SYSTEM JOINT COVER IN POLYCARBONATE

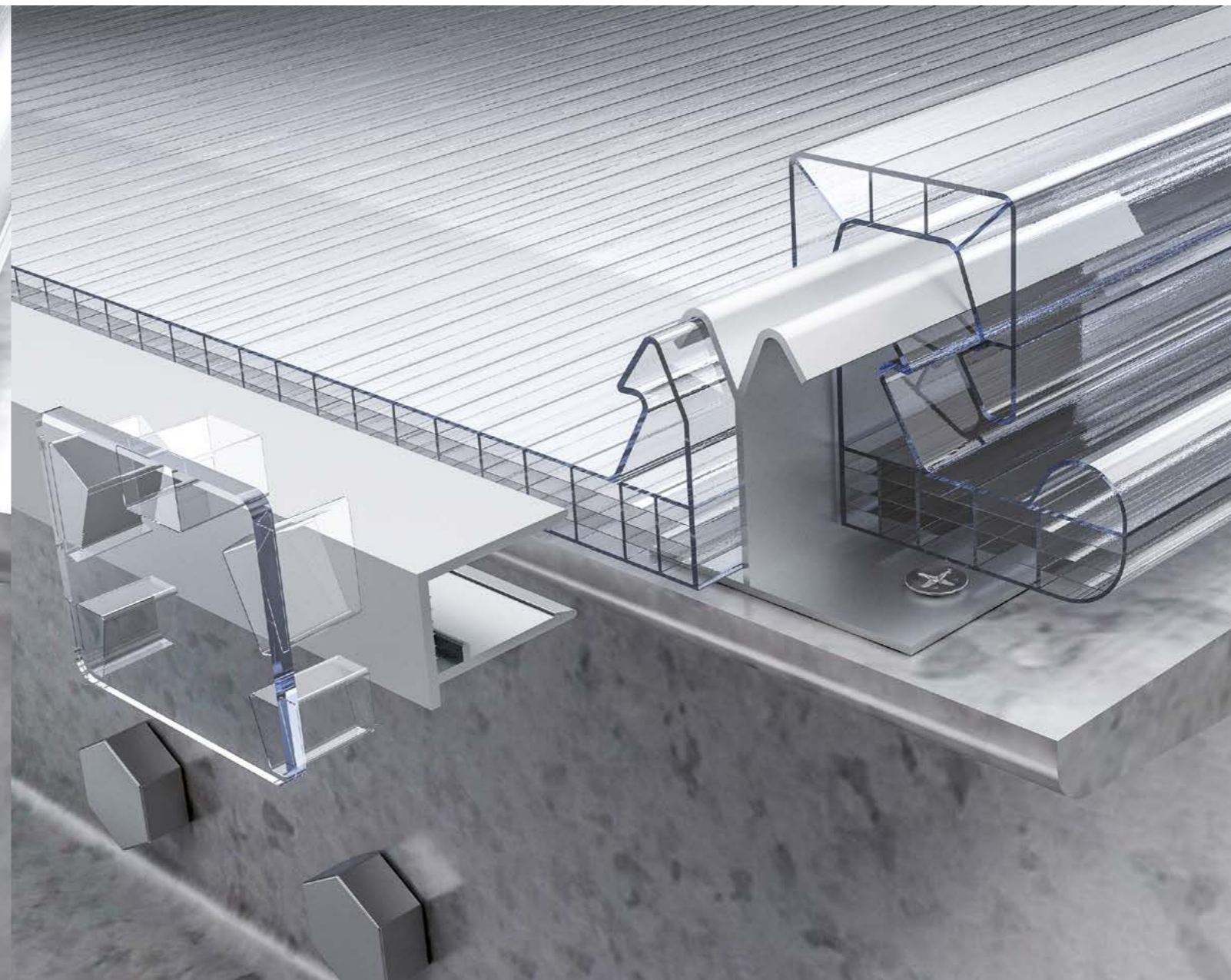

CLOSURE PROFILE DETAIL

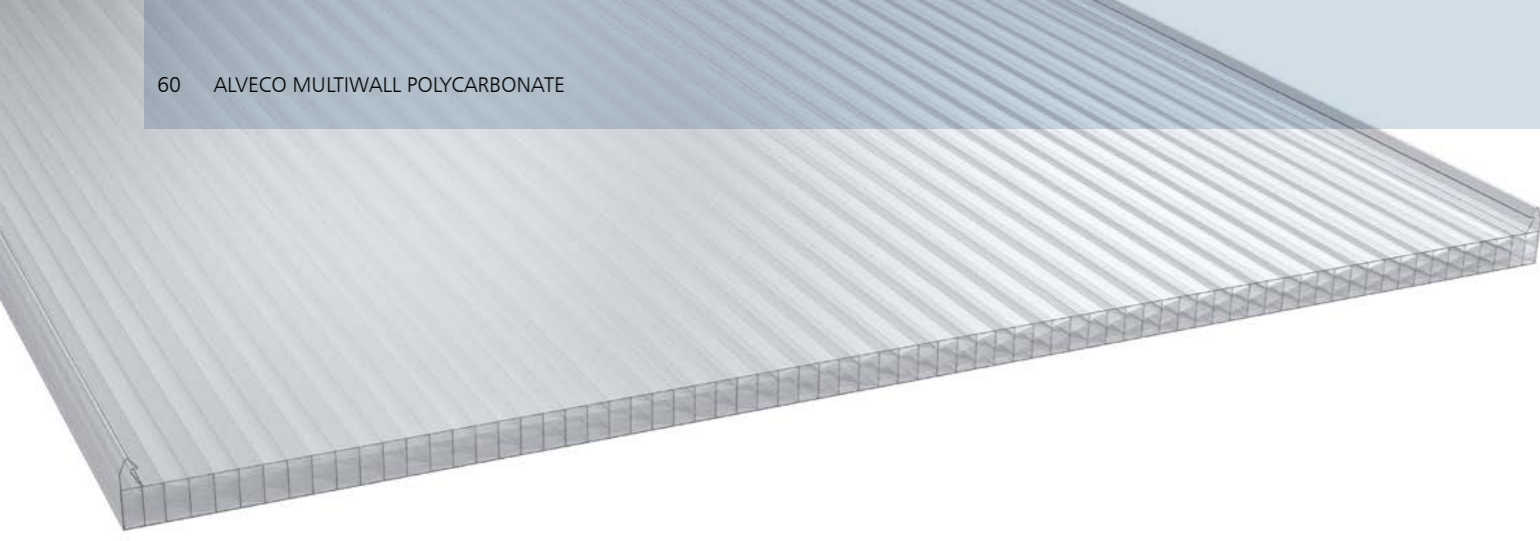

ALVE - WALL DUAL SYSTEM 1000

25/32/40 mm
CONNECTING JOINT SYSTEM

ALVE-WALL DUAL SYSTEM 1000 25 / 32 / 40 mm IS AN ALVEOLAR POLYCARBONATE SYSTEM, RECOMMENDED FOR THE CONSTRUCTION OF TRANSLUCENT ROOFS AND COVERINGS AND VERTICAL INFILL PANELS. THE SYSTEM IS COMPOSED OF PANELS IN ALVEOLAR POLYCARBONATE WITH 10-WALLS DIAGONAL STRUCTURE, 25 mm THICK, 32 mm THICK, 40 mm THICK, MODULE WIDTH 1000 mm, UV PROTECTED AND CO-EXTRUDED ON THE OUTER SIDE.

TECHNICAL SPECIFICATIONS

ALVE-WALL DUAL SYSTEM 1000 25 / 32 / 40 mm IS COMPOSED OF: PANEL IN MULTIWALL POLYCARBONATE UV PROTECTED, CO-EXTRUDED ON TWO SIDES, 10-WALLS DIAGONAL STRUCTURE, COLOR ON REQUEST. DIMENSIONS: MODULE WIDTH 1000 mm, LENGTH CUT TO SIZE.

- JOINING PROFILE IN POLYCARBONATE.
- ALUMINUM PLATE FOR PANEL FASTENING.
- CAP IN ALUMINUM/POLYCARBONATE FOR ALVEOLI CLOSURE.

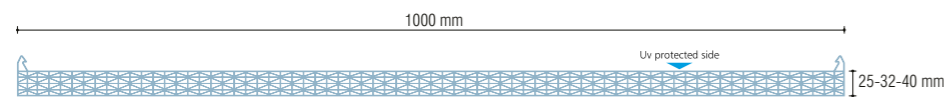

Thickness	25 mm	32 mm	40 mm
Width	1000 mm	1000 mm	1000 mm
Length	On request	On request	On request
Color	Crystal / Opal	Crystal / Opal	Crystal / Opal
Light transmission	Crystal 58% Opal 40%	Crystal 55% Opal 39%	Crystal 49% Opal 38%
Thermal transmittance	1,30 W/m ² K	1,10 W/m ² K	1,00 W/m ² K
Linear expansion	0,065 mm/m °C	0,065 mm/m °C	0,065 mm/m °C
Fire resistance certification EN 13501-1	B-s1,d0	B-s1,d0	B-s1,d0
Operating temperature	min -30 °C / max +120 °C	min -30 °C / max +120 °C	min -30 °C / max +120 °C

52 MM PROFILE

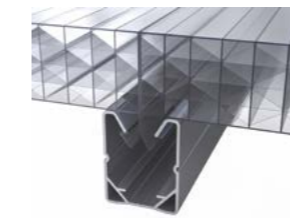

37 MM PROFILE

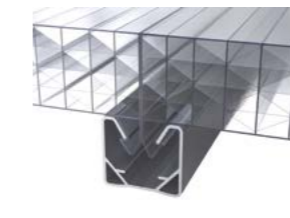

THICKNESS 25/32/40 mm PERMISSIBLE LOADS ON 2 SUPPORTS

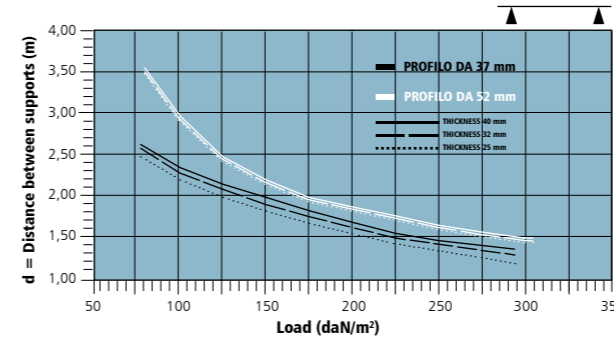

THICKNESS 25/32/40 mm PERMISSIBLE LOADS ON MULTIPLE SUPPORTS

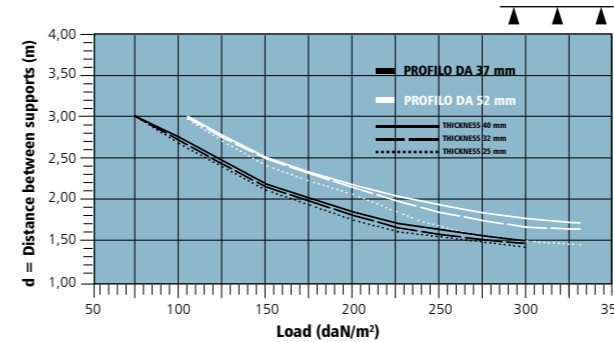

THICKNESS 25 mm PERMISSIBLE LOADS ON 2 SUPPORTS r. 4000mm

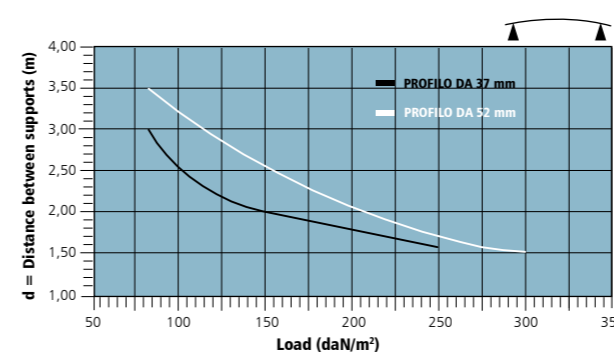

System resistance with evenly distributed load. The graph refers to a correct installation according to the Technical Manual.

JOINT COVER IN POLYCARBONATE

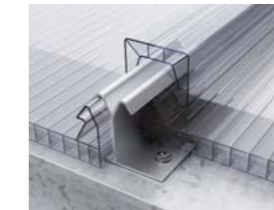

CONNECTOR IN ALUMINUM

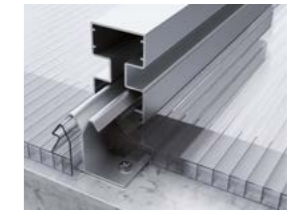

THICKNESS 25/32/40 mm PERMISSIBLE LOADS ON 2 SUPPORTS

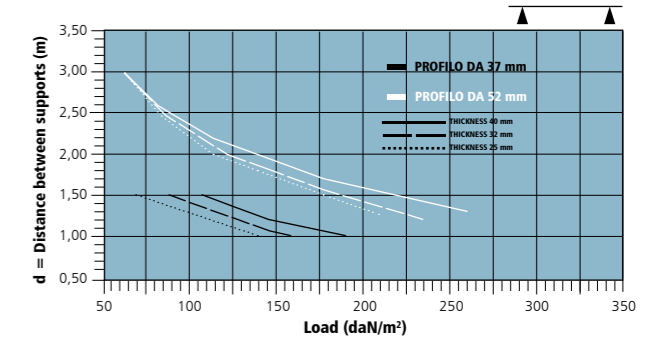

THICKNESS 25/32/40 mm PERMISSIBLE LOADS ON MULTIPLE SUPPORTS

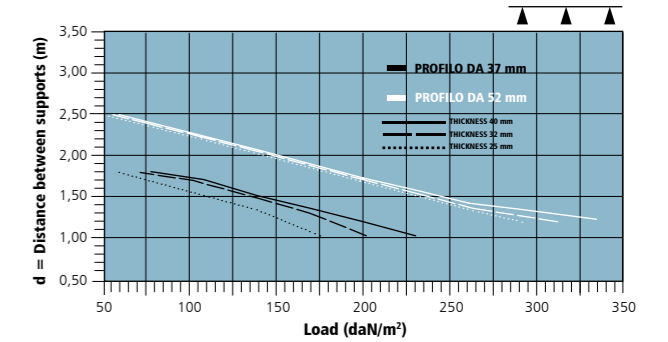

ALVEWALL SYSTEM 600 ACCESSORIES



CLOSURE PROFILE
DUAL SYSTEM IN ALUMINUM
10 mm



PC END PROFILE
FOR REVERSE 600
10 mm



CLOSURE PROFILE
DUAL SYSTEM IN ALUMINUM
16 mm



PC END PROFILE
FOR REVERSE 600
16 mm



CLOSURE PROFILE
DUAL SYSTEM IN ALUMINUM
20 mm

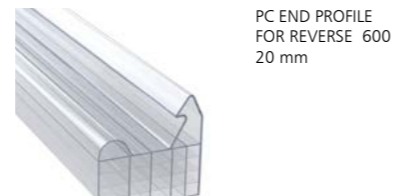

PC END PROFILE
FOR REVERSE 600
20 mm



JOINING PROFILE IN
ALUMINUM
H 37 mm



JOINING PROFILE PC



JOINING PROFILE IN
ALUMINUM
H 52 mm



CLOSURE CAP
DUAL WALL
SYSTEM



FASTENING PLATE
10/ 16 mm

FASTENING PLATE
20/ 25/ 32/ 40 mm



CLOSURE PROFILE
DUAL SYSTEM 600
IN ALUMINUM
25 mm

ALVEWALL SYSTEM 1000 ACCESSORIES



CLOSURE PROFILE
DUAL SYSTEM 1000
IN ALUMINUM
25 mm



PC END PROFILE
FOR REVERSE 1000
25 mm

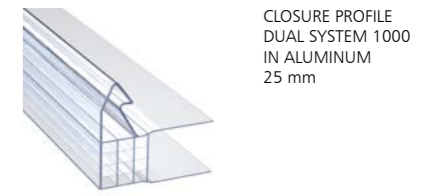

CLOSURE PROFILE
DUAL SYSTEM 1000
IN ALUMINUM
25 mm



CLOSURE PROFILE
DUAL SYSTEM 1000
IN ALUMINUM
32 mm



PC END PROFILE
FOR REVERSE 1000
32 mm



CLOSURE PROFILE
DUAL SYSTEM 1000
IN ALUMINUM
40 mm



PC END PROFILE
FOR REVERSE 1000
40 mm



JOINING PROFILE IN
ALUMINUM
H 37 mm



JOINING PROFILE PC

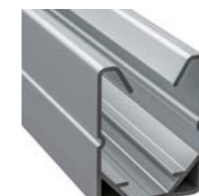

JOINING PROFILE IN
ALUMINUM
H 52 mm



CLOSURE CAP
DUAL WALL
SYSTEM



CONNECTOR IN
ALUMINUM



FASTENING PLATE
10/ 16/ 20/ 25/ 32/ 40 mm

ALVECOMP

SPECIAL SHEETS IN COMPACT POLYCARBONATE

APPLICATIONS

TRANSPARENCY, LIGHTNESS AND THERMAL INSULATION PROVIDE THE NECESSARY CHARACTERISTICS TO THE ALVECOMP PRODUCTS TO MEET BOTH THE TECHNICAL-APPLICATION SOLUTIONS REQUESTED AND THE REGULATIONS IN FORCE FOR THE DESIGN AND RESTORATION OF CIVIL AND INDUSTRIAL BUILDINGS:

- HIGH THERMAL INSULATION;
 - LIGHT MANAGEMENT;
 - EXCELLENT FIRE BEHAVIOR;
 - EXCELLENT SELF-WEIGHT/MECHANICAL STRENGTH RATIO;
 - EXCELLENT LOAD RESISTANCE PERFORMANCE;
 - UNCHANGED PHYSICAL/MECHANICAL PROPERTIES OVER TIME;
- THANKS TO THESE CHARACTERISTICS, THE ALVECOMP SHEETS ARE THE IDEAL SOLUTION FOR A VARIETY OF APPLICATIONS: DOORS, WINDOWS AND SHUTTERS, SKYLIGHTS, ROOFS, COVERINGS, CURTAIN WALLS, FALSE CEILINGS AND PARTITION WALLS.

TRANSPARENCY

THE PHYSICAL CHARACTERISTICS OF POLYCARBONATE PROVIDE TO THE ALVECOMP PRODUCT THE ABILITY TO CONVEY INSIDE BUILDINGS A HIGH PERCENTAGE OF LIGHT, WHICH THANKS TO SPECIAL PIGMENTS CAN BE MANAGED ACCORDING TO DESIGN NEEDS.

LIGHTNESS

THE LOW SPECIFIC WEIGHT OF POLYCARBONATE MAKES THE ALVECOMP PRODUCT VERY LIGHT, MINIMIZING LABOR COSTS FOR INSTALLATION OF THE PRODUCT AND ENHANCING LOAD RESISTANCE PERFORMANCE.

GLASS COMPARISON TABLE

	Weight Kg/m ²
Glass thickness 4 mm	10,0
Polycarbonate thickness 4 mm	4,8

IMPACT RESISTANCE COMPARISON TABLE

	Charpy without score marks ISO 179 (kJ/m ²)	Plzod with score marks ISO180 (kJ/m ²)
Glass	2	-
Tempered glass	10	-
Polycarbonate	no breaking	70

THERMAL INSULATION

MULTIPLE-WALL DRAWINGS AND THICKNESSES THAT POPULATE THE WIDE RANGE OF THE ALVECOMP PRODUCT COMBINED WITH THE CHEMICALPHYSICAL CHARACTERISTICS OF POLYCARBONATE MINIMIZE THERMAL EXCHANGE, ENHANCING PRODUCT PERFORMANCE AND METING THE REGULATIONS IN FORCE IN TERMS OF ENERGY SAVINGS.

IMPACT RESISTANCE

THE MECHANICAL CHARACTERISTICS OF POLYCARBONATE PROVIDE TO THE ALVECOMP PRODUCT HIGH IMPACT RESISTANCE, WHICH IS OPTIMIZED AGAINST DAMAGES CAUSED BY WEATHER AGENTS AND ACCIDENTAL IMPACTS, MEETING THE REGULATIONS IN FORCE IN TERMS OF SAFETY.

FIRE BEHAVIOR

ALVECOMP IS CLASSIFIED EURO CLASS B-S1,D0.

GUARANTEE OVER TIME

THE MODERN PLANTS USED BY ALVECO, EQUIPPED WITH THE MOST RECENT AND ADVANCED TECHNOLOGY FOR THE MANUFACTURING OF ALVEOLAR SHEETS ALLOW PRODUCING THE ALVECOMP PRODUCT WITH UV PROTECTION ON BOTH SIDES BY APPLYING THE UV ABSORBER, WHICH PROTECTS THE SHEET FROM AGING CAUSED BY UV RAYS.

THE UV PROTECTION HINDERS THE DEGRADATION OF THE SHEET, PRESERVING THE ALVECOMP PRODUCT FROM LOSS OF MECHANICAL CHARACTERISTICS, BRIGHTNESS AND TRANSPARENCY. THE ALVECOMP PRODUCT IS GUARANTEED FOR A 10-YEAR PERIOD

THERMAL CONDUCTIVITY COMPARISON TABLE

	Thermal conductivity λ
Glass	1,30 W/m ² K
Polycarbonate	0,20 W/m ² K

BENDING RADIUS

THE ALVECOMP SHEETS OFFER A WIDE RANGE OF APPLICATIONS FOR USE, AMONG WHICH COLD BENDING OF THE SHEET TO MAKE IT SUITABLE TO THE USE AS AN ELEMENT TO CREATE CURVED SKYLIGHTS, SMALL DOMES AND TUNNELS.

THE MINIMUM SAFETY VALUE IS:

150 TIMES THE THICKNESS OF THE SLAB FOR THICKNESSES FROM 2 TO 6 mm

FOR GREATER THICKNESSES, THE LENGTH OF THE SHEET IS RELEVANT. PLEASE CONTACT OUR TECHNICAL DEPARTMENT FOR FURTHER INFORMATION.



ALVECOMP

SPECIAL SHEETS IN COMPACT POLYCARBONATE

CUTTING

ALVECOMP COMPACT POLYCARBONATE SHEETS CAN BE CUT WITH STANDARD CUTTING TOOLS SUCH AS VERTICAL AND HORIZONTAL SHEARING MACHINES, CIRCULAR SAWS, BAND SAWS OR JIG SAWS. IN ANY CASE, IT IS NECESSARY TO PAY EXTREME ATTENTION TO LOCK THE BLADE IN SUCH A WAY TO MINIMIZE VIBRATIONS AND LOCAL TWISTING.

CIRCULAR SAW – RECOMMENDED PARAMETERS

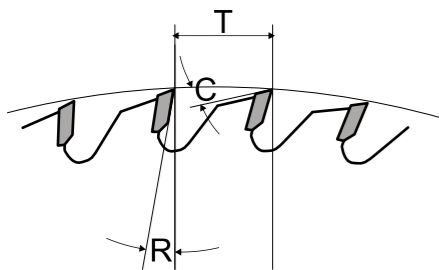

Cutting angle	C	20° - 30°
Clearance angle	R	0° - 5°
Tooth pitch	T	9 - 15 mm
Blade speed		1800-2400 m/min
Forward movement speed		max 22 m/min(*)

(*) reference speed for 3 mm thickness

BAND SAW – RECOMMENDED PARAMETERS

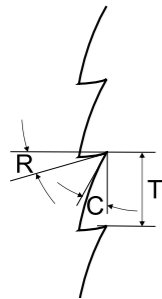

Cutting angle	C	20° - 30°
Clearance angle	R	0° - 5°
Tooth pitch	T	1,5 - 4 mm
Blade speed		600-1000 m/min
Forward movement speed		max 22 m/min(*)

(*) reference speed for 3 mm thickness

TO DRILL THE ALVECOMP PRODUCT IS RECOMMENDED TO USE HELICAL BITS IN STEEL SUITABLE TO DRILL PLASTIC MATERIALS.

DRILLING – RECOMMENDED PARAMETERS

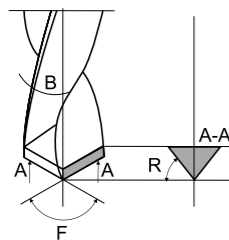

Clearance angle	R	0° - 15°
Drill bit angle	F	120° - 160°
Twist angle	B	20° - 40°
Forward movement speed		0,1 - 0,3 mm/rev

(*) reference speed for 3 mm thickness

ROTATION SPEED

Hole diameter	Rotation speed
3 mm	1750 rpm/min
6 mm	1500 rpm/min
9 mm	1000 rpm/min
12 mm	650 rpm/min
18 mm	350 rpm/min

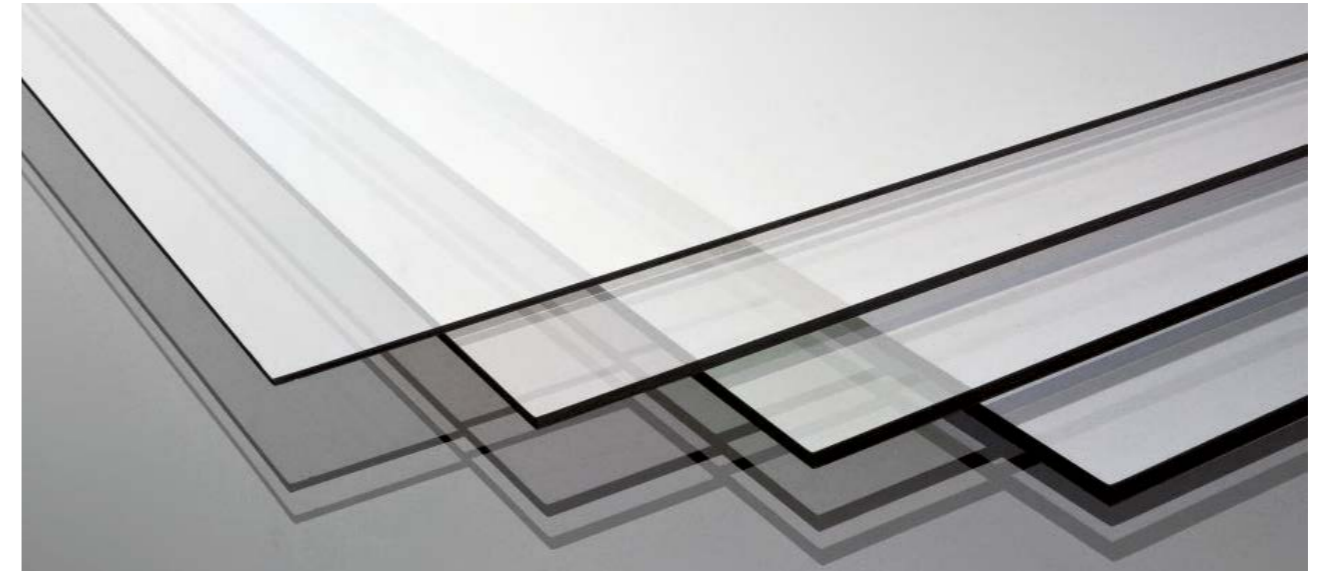

BENDING

ALVECOMP SHEETS CAN BE COLD-BENT USING SPECIAL EQUIPMENT.

RECOMMENDED PARAMETERS
(ambient temperature 20°C)

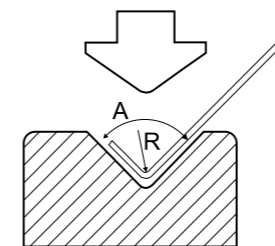

SHEET thickness (mm)	Bending radius R (mm)	Minimum angle (A)
3 - 4	3	90°
5 - 5	5	90°

IN THE BENDING POINT THE UV PROTECTION IS COMPROMISED. THIS PROCESSING IS NOT RECOMMENDED FOR SHEETS THAT MUST BE INSTALLED UNDER DIRECT EXPOSURE TO UV RAYS.

THERMOFORMING

ALVECOMP SHEETS CAN BE HOT THERMOFORMED. TO DO SO IT IS IMPORTANT TO FOLLOW A FEW RECOMMENDATIONS:

- PRIOR DRYING OF THE SHEETS AT A TEMPERATURE OF APPROX. 120°C;
- REMOVAL OF PROTECTION FILM PRIOR TO THERMOFORMING;
- THERMOFORMING TEMPERATURE RANGING BETWEEN 175° AND 200°C;

THE THERMOFORMING OPERATION CAUSES STRETCHING BOTH IN TERMS OF THICKNESS AND COEXTRUSION LAYER THUS IT IS IMPORTANT TO ASSESS WITH CARE THE LIMITATIONS OF USE FOR EACH PROJECT. THE SHEET SUBJECTED TO THIS PROCESSING IS NO LONGER UNDER STANDARD WARRANTY.

ALVECOMP

SPECIAL SHEETS IN COMPACT POLYCARBONATE

MECHANICAL PROPERTIES	VALUE	UNIT	REGULATION	
Tensile strength at yield SY	>60	N/mm ²	DIN 53455	
Tensile strength at rupture SR	>70	N/mm ²	DIN 53455	
Elongation at yield EY	6	%	DIN 53455	
Elongation at rupture ER	>100	%	DIN 53455	
Tensile modulus of elasticity E	2300	N/mm ²	DIN 53457	
Impact resistance AN	+23°C	65	kJ/m ²	DIN 53453
	-40°C	65	kJ/m ²	DIN 53453
Resilience AK at +23°C	35	kJ/m ²	DIN 53453	
Izod impact resistance with score marks	>700	J/m	ASTM 256-56	
Brinell Harness H30	110	N/mm ²	DIN 53456	
PHYSICAL PROPERTIES	VALUE	UNIT	REGULATION	
Density	1.2	g/cm ³	DIN 53479	
ND refraction index	1.58	no	DIN 53491	
Water absorption by immersion	0.36	%	DIN 53495	
Permeability to water vapor (0,1mm)	15	g/m ² d	DIN 53122	
THERMAL PROPERTIES	VALUE	UNIT	REGULATION	
Linear Thermal Expansion A	0.065	mm/m °C	DIN 53752	
Thermal conductivity λ	0.2	W/m K	DIN 52612	
Softening temperature VICAT	145-150	°C	DIN 53460	

Typical polycarbonate material values

FORMATS AND TRANSMITTANCE

Thickness	Weight Kg/m ²	Standard formats width mm	Standard formats length mm	Light transmittance LT (%)		
				Crystal	Opal	Bronze
2 mm	2.4	2,050	3,050	90	72	71
			6,100			
3 mm	3.6	2,050	3,050	89	60	52
			6,100			
4 mm	4.8	2,050	3,050	88	52	50
			6,100			
5 mm	6.0	2,050	3,050	88	46	44
			6,100			
6 mm	7.2	2,050	3,050	88	40	42
			6,100			
8 mm	9.6	2,050	3,050	87	31	34
			6,100			
10 mm	12.0	2,050	3,050	86	22	30
			6,100			
12 mm	14.4	2,050	3,050	86	16	24
			6,100			
15 mm	18.0	2,050	3,050	80	14	22
			6,100			
20 mm	24.0	2,050	3,050	76	12	18
			6,100			

ACOUSTIC INSULATION AND FIRE REACTION CERTIFICATION EN 13501-1

Thickness	Acoustic insulation	Fire reaction class Clear and Opal
2 mm	25 dB	B-s1 d0
3 mm	26 dB	B-s1 d0
4 mm	27 dB	B-s1 d0
5 mm	28 dB	B-s1 d0
6 mm	29 dB	B-s1 d0
8 mm	31 dB	NDP
10 mm	32 dB	NDP
12 mm	34 dB	NDP
15 mm	36 dB	NDP
20 mm	40 dB	NDP

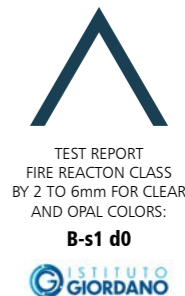



ALVECOLAR

MULTIWALL POLYCARBONATE SHEETS

APPLICATIONS

TRANSPARENCY, LIGHTNESS AND THERMAL INSULATION PROVIDE THE NECESSARY CHARACTERISTICS TO THE ALVECOLAR PRODUCT TO MEET BOTH THE TECHNICAL-APPLICATION SOLUTIONS REQUESTED AND THE REGULATIONS IN FORCE FOR THE DESIGN AND RESTORATION OF CIVIL AND INDUSTRIAL BUILDINGS:

- HIGH THERMAL INSULATION;
- LIGHT MANAGEMENT
- EXCELLENT FIRE BEHAVIOR;
- EXCELLENT SELF-WEIGHT/MECHANICAL STRENGTH RATIO;
- EXCELLENT LOAD RESISTANCE PERFORMANCE;
- UNCHANGED PHYSICAL/MECHANICAL PROPERTIES OVER TIME;

THANKS TO THESE CHARACTERISTICS, THE ALVECOLAR SHEETS ARE THE IDEAL SOLUTION FOR A VARIETY OF APPLICATIONS: DOORS, WINDOWS AND SHUTTERS, SKYLIGHTS, ROOFS, COVERINGS, CURTAIN WALLS, FALSE CEILINGS AND PARTITION WALLS.

TRANSPARENCY

THE PHYSICAL CHARACTERISTICS OF POLYCARBONATE PROVIDE TO THE ALVECOLAR PRODUCT THE ABILITY TO CONVEY INSIDE BUILDINGS A HIGH PERCENTAGE OF LIGHT, WHICH THANKS TO SPECIAL PIGMENTS CAN BE MANAGED ACCORDING TO DESIGN NEEDS.

LIGHTNESS

THE LOW SPECIFIC WEIGHT OF POLYCARBONATE MAKES THE ALVECOLAR PRODUCT VERY LIGHT, MINIMIZING LABOR COSTS FOR INSTALLATION OF THE PRODUCT AND ENHANCING LOAD RESISTANCE PERFORMANCE.

TECHNICAL CHARACTERISTICS

Reaction to fire	EUROCLASS B s1 d0
Linear expansion	0,065 mm/m°C
Operating temperature	-30°C + 120°C
Vicat (B/50)	150°C

LIGHT TRANSMITTANCE LT (%)

Structure	Thickness	Crystal %	Bronzo %	Opal %
2 W	4	84	65	55
2 W	6	82	62	51
2 W	8	80	62	50
2 W	10	80	60	48
5 W/X	16	65	40	55
5 W/X	20	60	30	40
5 W/X	25	60	28	40
10 W/X	16	55	38	37
10 W/X	20	52	34	34
10 W/X	25	50	32	34
10 W/X	32	48	30	31
10 W/X	40	45	26	28

THERMAL INSULATION

MULTIPLE-WALL DRAWINGS AND THICKNESSES THAT POPULATE THE WIDE RANGE OF THE ALVECOLAR PRODUCT COMBINED WITH THE CHEMICALPHYSICAL CHARACTERISTICS OF POLYCARBONATE MINIMIZE THERMAL EXCHANGE, ENHANCING PRODUCT PERFORMANCE AND METING THE REGULATIONS IN FORCE IN TERMS OF ENERGY SAVINGS.

IMPACT RESISTANCE

THE MECHANICAL CHARACTERISTICS OF POLYCARBONATE PROVIDE TO THE ALVECOLAR PRODUCT HIGH IMPACT RESISTANCE, WHICH IS OPTIMIZED AGAINST DAMAGES CAUSED BY WEATHER AGENTS AND ACCIDENTAL IMPACTS, MEETING THE REGULATIONS IN FORCE IN TERMS OF SAFETY.



FIRE BEHAVIOR

ALVECOLAR IS CLASSIFIED EURO CLASS B-S1,D0.

GUARANTEE OVER TIME

THE MODERN PLANTS USED BY ALVECO, EQUIPPED WITH THE MOST RECENT AND ADVANCED TECHNOLOGY FOR THE MANUFACTURING OF ALVEOLAR SHEETS ALLOW PRODUCING THE ALVECOLAR PRODUCT WITH UV PROTECTION ON BOTH SIDES BY APPLYING THE UV ABSORBER, WHICH PROTECTS THE SHEET FROM AGING CAUSED BY UV RAYS.

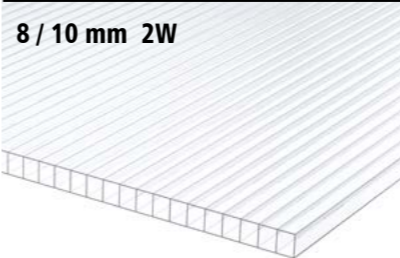
THE UV PROTECTION HINDERS THE DEGRADATION OF THE SHEET, PRESERVING THE ALVECOLAR PRODUCT FROM LOSS OF MECHANICAL CHARACTERISTICS, BRIGHTNESS AND TRANSPARENCY. THE ALVECOLAR PRODUCT IS GUARANTEED FOR A 10-YEAR PERIOD.

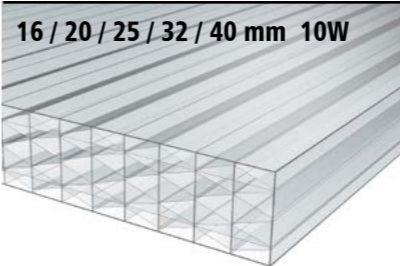
Section	Thickness	Width	Length	Weight kg/m ²	U termico W/m ² k
 4 / 6 mm 2W	4 mm	2.100	6.000	0,80	3,90
	6 mm	2.100	6.000	1,30	3,60
 8 / 10 mm 2W	8 mm	980	6.000	1,50	3,30
		1.500	6.000	1,50	3,30
		2.100	6.000	1,50	3,30
	10 mm	980	6.000	1,70	2,60
		1.500	6.000	1,70	2,60
		2.100	6.000	1,70	2,60
16 mm	980	6.000	2,50	2,00	
	1.500	6.000	2,50	2,00	
	2.100	6.000	2,50	2,00	
 16 / 20 / 25 mm 5W	20 mm	980	6.000	3,10	1,80
		1.500	6.000	3,10	1,80
		2.100	6.000	3,10	1,80
	25 mm	980	6.000	3,10	1,60
		1.500	6.000	3,10	1,60
		2.100	6.000	3,10	1,60
 16 / 20 / 25 / 32 / 40 mm 10W	16 mm	2.100	6.000	2,80	1,70
	20 mm	2.100	6.000	3,20	1,50
		2.100	6.000	3,40	1,30
	25 mm	2.100	6.000	3,70	1,10
		2.100	6.000	4,20	1,00

ALVECOLAR LOADING CAPACITY TABLES

SPECIAL SHEETS IN FLAT MULTIWALL POLYCARBONATE

ALVECOLAR CAPACITY

THE TABLES BELOW REPORT THE LOAD VALUES FOR SHEETS ANCHORED ON FOUR SIDES.

ALVECOLAR 6 mm 2P

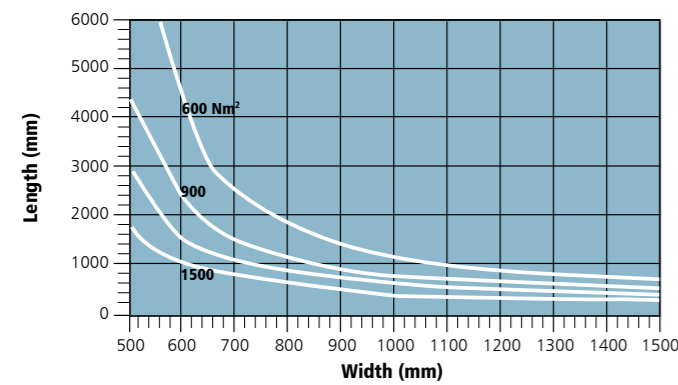

ALVECOLAR 8 mm 2P

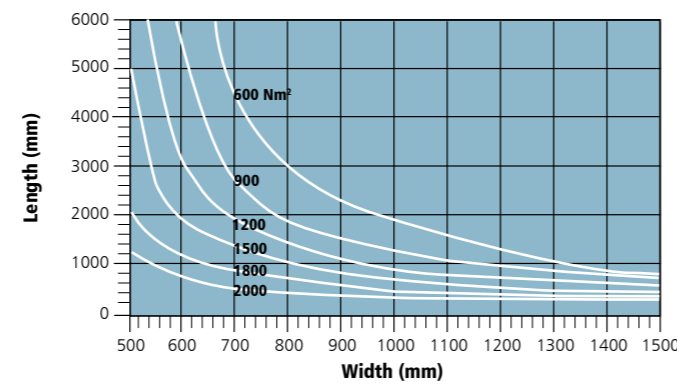

ALVECOLAR 20/25 mm 10PX

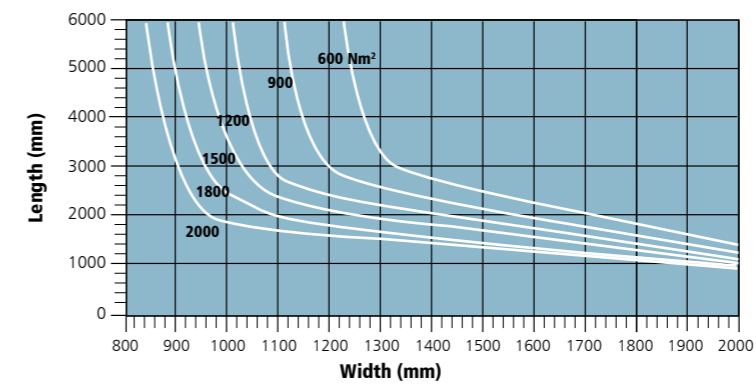

ALVECOLAR 10 mm 2P

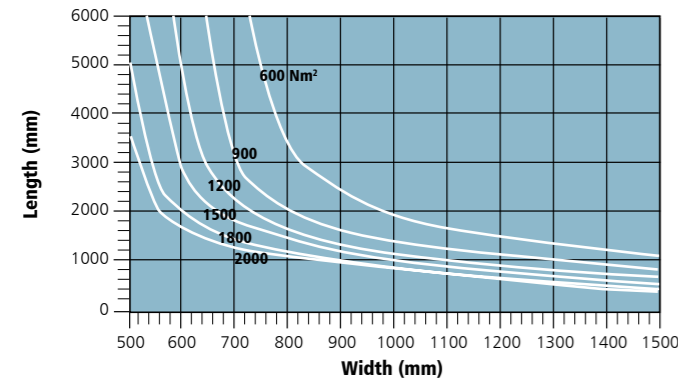

ALVECOLAR 32/35 mm 10PX

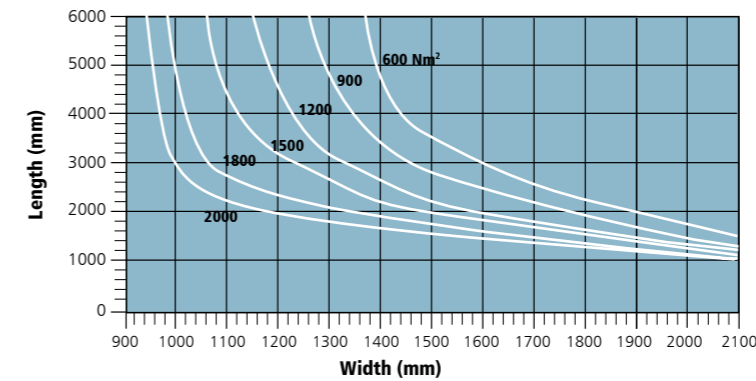

ALVECOLAR 16 mm 5PX / 10 PX

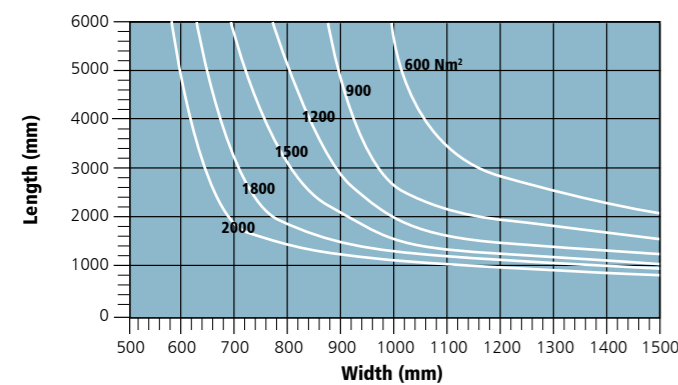

ALVECOLAR 20 mm 5PX

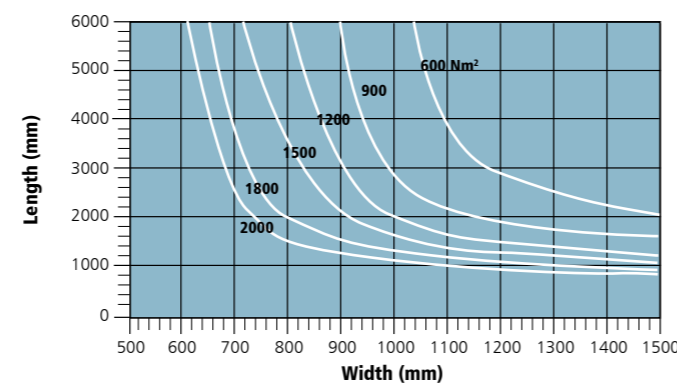

ALVECOLAR 40 mm 10PX

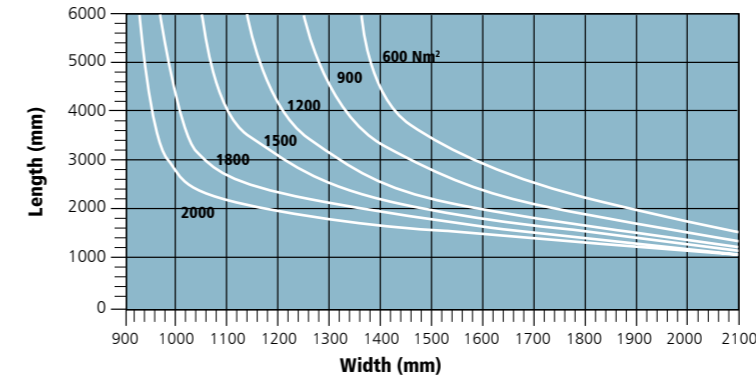

ALVECOLAR

SPECIAL SHEETS IN CURVED MULTIWALL POLYCARBONATE

ALVECOLAR CAPACITY APPLICATION CURVE

THE GRAPHS SHOW THE PERMISSIBLE WIDTH OF THE SHEET BASED ON THE LOAD AND BENDING RADIUS

ALVECOLAR 6mm 2P

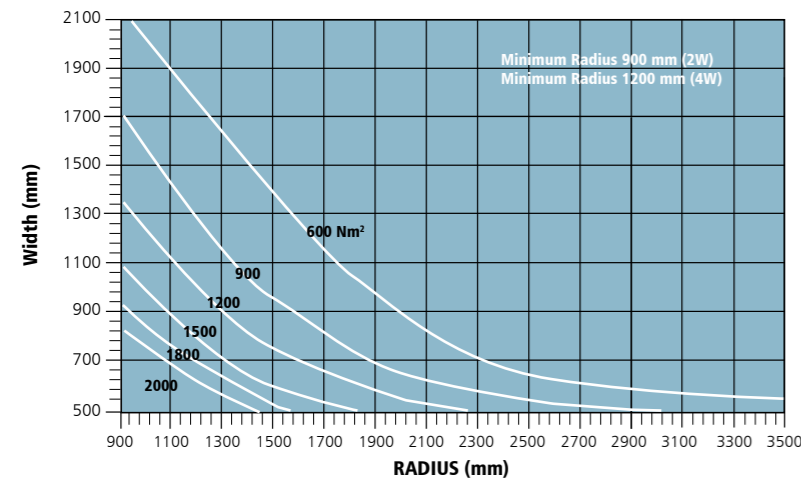

ALVECOLAR 8mm 2P

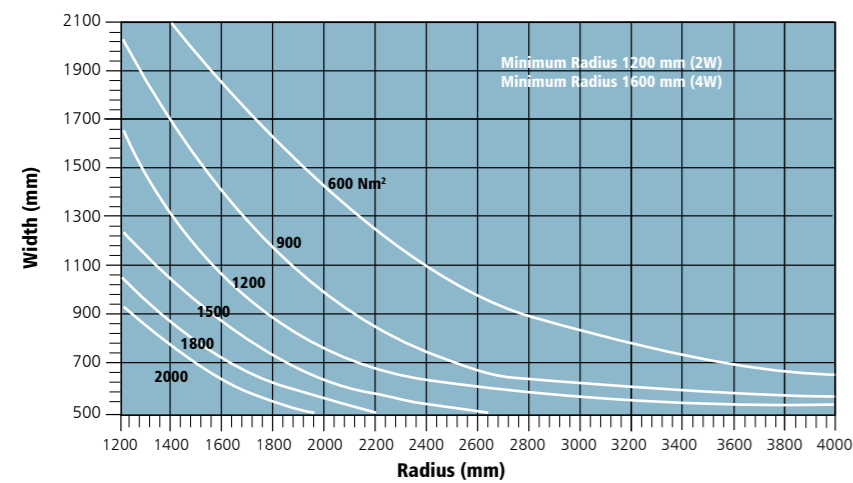

ALVECOLAR 10mm 2P

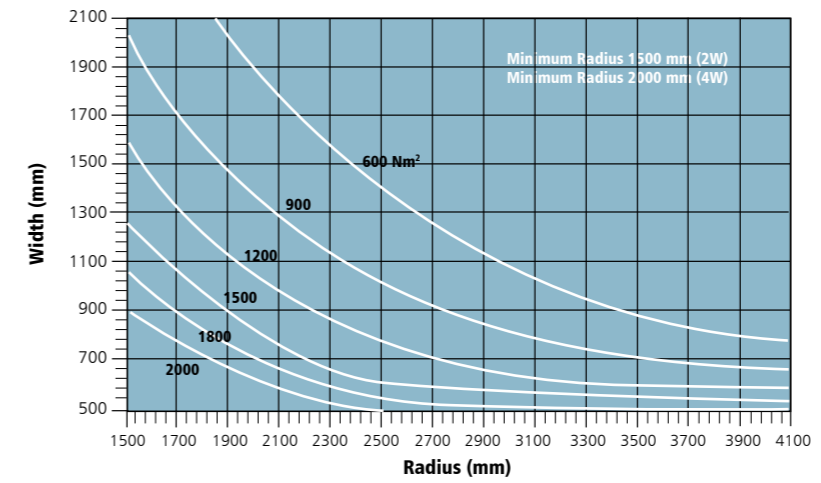

ALVECOLAR 16mm 5PX

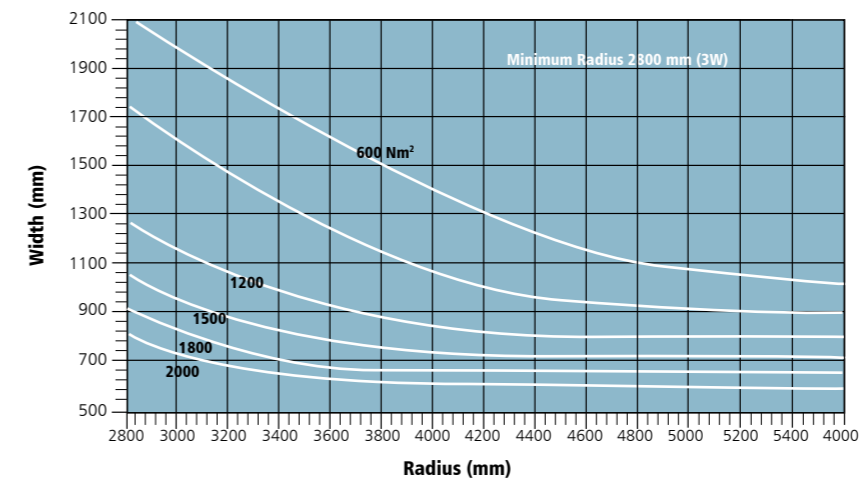

ALVECOLAR 20mm 5PX

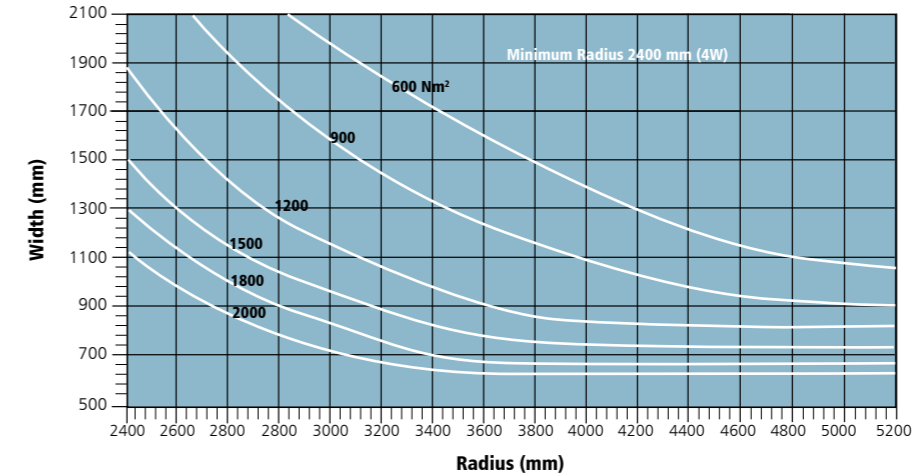

GENERAL TERMS AND CONDITIONS OF SALE

The **Seller** party is understood as ALVECO SRL, a manufacturer and/or supplier company of the products in question, which will issue an invoice for said products.

The **Buyer** party is understood as the addressee of the invoices related to the products in question.

1 Purpose

1.1 All sales of products and/or accessories ("Products") made by the Seller are subject to and governed by these General Terms and Conditions of Sale, except any special conditions agreed in writing between the Seller and the Buyer. These General Terms and Conditions of Sale shall prevail on any other document, clause, provision (even if not explicitly contested by the seller) contained in forms, quotes, orders of the Buyer including also any general terms of purchase.

1.2 All specifications, drawings, specifications of weight and dimensions and data related to the performance contained in any documentation of the Seller are to be considered indicative.

1.3 The Seller reserves the right to improve and/or modify specifications, drawings and dimensions without notice.

1.4 The information published on the website www.alveco.info represents the most up-to-date version regarding all the technical specifications related to the Products and the related updates, consequently what has been published there in prevails in any case on what has been published on paper.

1.5 These General Terms and Conditions of Sale are applicable to all sales contracts, even future ones, with the Buyer, unless specific written exceptions are agreed between the parties.

2. Order - Acceptance

2.1 All orders must be submitted in writing.

2.2 The Order Confirmation will be processed by the Seller only after the Buyer has sent to the Seller the order confirmation signed for acceptance.

3. Delivery, Shipping and Transportation of Materials

3.1 The delivery terms specified in each order confirmation are indicative and not binding for the Seller who assumes no responsibility for the delay, unless the term is specifically agreed in writing with the Seller. No delay may give rise to claims by the Buyer for compensation of direct or indirect damages.

3.2 If specific terms are agreed in writing as mandatory, any facts that may prevent or delay the production of the Products such as, but not limited to, strikes (including corporate strikes), lockouts, fires, import bans, delayed supply of raw materials or limitations of energy sources and other facts that may prevent or delay the manufacture, are conventionally considered as a force majeure and the Seller shall not be held responsible for the delay in delivery whose terms will be prorogued for the duration of the aforementioned situations. In no case can the orders be canceled by the Buyer.

3.3 In the cases indicated in article 3.2, the Seller must inform the Buyer without delay of the fact occurred, and may delay delivery should the causes of the delay persist. If the causes of the delay last longer than 30 (thirty) days, the Seller shall have the right to withdraw from the contract, without this implying the Buyer's right to compensation for damages directly or indirectly attributable to the delay.

3.4 Unless otherwise stated in the order confirmation, the Products are sold "ex works" by the Seller (loaded on the arriving vehicle). " The Products will be delivered in the Seller's standard packaging with labeling and standard marking. The commercial terms of transport will be interpreted according to Incoterms 2010 as published by the International Chamber of Commerce.

3.5 The Products, even if sold ex-works travel always at risk of the Buyer.

3.6 Upon delivery, the Buyer shall be obligated to check the Products. The Buyer undertakes to inspect the Products, in particular the quantity, the dimensions, the integrity of the packaging and the compliance with the order confirmation and if the delivery is free on site delivery it must notify any claim to the carrier at the time of delivery. Otherwise, it is assumed that the delivered products fully respect what has been ordered. Any claim or dispute raised by the Buyer must be followed by sending within eight (8) days of delivery/return of the product a complaint in writing to the Seller.

3.7 Failure to notify in writing the defects/shortcomings within the terms and according to the provisions of these General Terms and Conditions of Sale

entails loss of rights by the Buyer. The Buyer cannot refuse the goods unless they have serious quality defects or shortcomings such as to affect the use of the product.

3.8 The Seller shall not be responsible for defects caused by incorrect transportation of the Products.

3.9 After 8 (eight) days from the issuance of the notice of goods ready, an invoice will be issued, and payment terms will start as stated in the order confirmation.

4. Packaging and Protection

4.1 All materials are supplied with standard packaging. Any specific packaging must be requested at the time of order, specified in the Order Confirmation and will be charged on the invoice.

4.2 The Seller is held harmless from any liability in the event that the Buyer does not strictly follow the instructions of the Seller for storage and maintenance and/or those published on the website www.alveco.info

5. Tolerances

5.1 The Buyer accepts the tolerances shown in the Seller's catalogs and/or technical sheets delivered to the Buyer or published in the catalogs and/or on the website: www.alveco.info consequently no defect or fault can be claimed against the Seller if within said tolerances.

6. Warranty

6.1 The Seller guarantees that the Products sold match the technical specifications and/or technical sheets delivered to the Buyer and/or published in the catalogs and/or on the website: www.alveco.info and guarantees compliance with EU legislation where applicable as well as the absence of material and workmanship defects on the Products. Therefore, the Seller does not provide guarantees regarding the conformity of the products with the requirements prescribed by regulations other than Italian and/or European ones. The Seller does not guarantee in any way conformity of the products to standards, technical standards or regulatory provisions other than those specified in the product data sheet.

Therefore, it will be the sole responsibility of the Buyer to verify compliance of the products with the regulations and technical requirements of the countries in which it intends to use the products.

6.2 With regard to the technical instructions and updates as published on the website, what has been published on paper shall prevail.

6.3 The above warranty is valid for twelve months from the delivery of the products. Different warranty periods and warranty conditions must be specified in writing in the Order Confirmation.

6.4 The Products must be stored, handled and maintained in full respect of the instructions of the Seller's technical documentation, delivered and/or published in the catalogs or on the website: www.alveco.info. Therefore, the warranty shall be void if the products are installed in a non-compliant manner with the above instructions or installation diagrams and if they do not comply with the technical data sheets (latest edition) delivered and/or published in the catalogs and/or on the website.

6.5 Any claims concerning apparent defects of the Products must be reported in writing (by registered letter with return receipt or telegram, or certified email address) to the Seller within 8 (eight) days of delivery of the products, be it understood that the Buyer's warranty shall be void after this deadline has elapsed concerning defects and/or poor quality and/or non-compliance with the products sold. Any hidden defects, not detectable upon delivery of the Products, must be reported in writing to the Seller (by registered mail with return receipt or telegram, or certified email address advanced by e-mail/fax) within eight days of discovery and in any case within the term indicated in Article 6.3.

6.6 It is understood that any claims shall not give the Buyer the right to suspend

or in any case delay the payments of the Products subject to dispute or those related to other supplies.

6.7 Claims must be accompanied by explanations to allow the Seller to perform prompt and complete verification. The Products subject matter of the claim must be made available to the Seller, in the state in which they were delivered, in compliance with the "rules on transportation, handling and storage" as published in the catalogs and/or on the website: www.alveco.info and any other instructions provided by the Seller in writing.

6.8 The Seller in the case of defects, lack of quality, non-compliance of the product will be required to repair or replace the individual defective Product with replacement made in the contractually agreed location specified in the Order Confirmation or to compensate the Buyer within the limits of the amount agreed in the Order Confirmation for the individual defective product. It is understood that the aforementioned warranty (consisting of the obligation to repair or replace the individual Product or reimbursement within the limits of the agreed price for the defective Product) is in lieu and substitution of any other guarantee by law and excludes any other responsibility of the Seller (both contractual and extra contractual) however originated from the Products supplied (for example compensation for direct and/or indirect damages, loss of earnings, recalls etc.)

6.9 The Buyer's right to terminate the contract as a result of any defects in the Products is excluded.

6.10 In the case of supply in partial deliveries, any claims, even if timely, do not exempt the Buyer from the obligation to pick up and pay the remaining quantity of products ordered.

6.11 The Seller's warranty does not extend to the repaired and/or replaced parts or to the products supplied as a replacement.

6.12 The Seller warrants the absence of defects in material and craftsmanship and that the Products are within the tolerances specified in art. 5 consequently the Seller does not guarantee any aesthetic result originating from the laying of the Products and the Seller cannot be charged in any case any differences in installation, interlocking, alignment between the Products.

6.13 The Buyer must comply with the Seller's instructions regarding storage, handling, assembly and maintenance of the Product as published in the catalogs and/or on the website www.alveco.info. The calculation data, table values, bills of material, drawings, and any other document provided by the Seller, even as mere advice, shall be considered as simple general elements and do not give rise to any liability of the Seller, the design, project management and testing remaining under the exclusive competence, responsibility and care of the Buyer.

6.14 Any warranty referred to in this art. 6 is no longer valid and becomes void if:

a) The Product is used in a manner that does not comply with its performance characteristics as set out in the technical data sheets published in the catalogs and/or on the website.

b) Failure by the Buyer to comply with the assembly, storage, handling and maintenance instructions as published in the catalogs and/or on the www.alveco.info website. Under no circumstance the products that are defective shall be used in any way by the Buyer or the Buyer forfeits all warranty rights.

c) Installation carried out by adopting systems, accessories not in compliance with the Seller's technical sheets attached to the catalogs and/or published on the site or using accessories not supplied and/or not expressly approved by the Seller;

d) Interventions of any kind performed by third parties other than the Seller, on the Product after delivery;

e) Use and/or installation of the alleged defective Product by the Buyer, following the claim and/or dispute;

f) Faults and defects not confirmed as such according to the state of the art and science at the time of placing the Products on the market.

6.15 Special warranties and/or certifications may be issued only if requested by the Buyer when the order is placed and if specifically accepted in the Seller's order confirmation.

6.16 The Products only perform the function of roof/coverings and/or improvement of energy level of the building, and unless otherwise expressly agreed in writing with the Seller, do not contribute in any way to the overall or partial stability of the structure of the building. Therefore, they are not suitable for supporting vertical - horizontal loads or permanent static loads (excluding their own weight). The Buyer must assess and size the existing supporting

structure, in order to ascertain its suitability and hold harmless the Seller from any and all liability.

6.17 The Seller reserves the right to make the necessary technical changes or improvements to its production.

6.18 The Products subject to dispute must be kept available to the Seller to allow a joint and out-of-court assessment, at no charge from the Buyer to the Seller.

7. Payments

Every delivery will be invoiced.

7.1 The methods of payment are those specified in the order confirmation. All Payments must be made to the Seller's account. All payments made before delivery or before the invoice deadline are considered an advance on the final price, and remain acquired by the Vendor regardless of the outcome of the order.

7.2 The collection by the Seller of amounts paid upon ordering does not constitute acceptance of the same. If the Seller does not accept the order, for reasons not attributable to the Buyer, the Seller shall return the amounts collected, without interest.

7.3 In the event of non-fulfillment by the Buyer and consequent termination of the contract, the amounts paid in advance shall be retained by the Seller as a penalty without prejudice to the right to compensation for greater damages;

7.4 In the case of late payments, the Buyer shall pay, in accordance with Legislative Decree 231/02, interest for late payment, in addition to the compensation for costs

7.5 If the payment of the products is planned through bills of exchange or securities (checks, bills of exchange at the official reference rate plus seven points, starting from the deadline of the agreed term, etc.), these must reach the Seller's office before or simultaneously with the pick up of the Products.

7.6 In the case of payment in installments, in the event of non-payment on the expected deadline of only a portion of the price, the Buyer shall lose the benefit of the payment extension ("benefit of the term") and the Seller may request immediate payment of all the amount due in a single installment. The statement sent by the Seller is understood as accepted by the Buyer, if it has not been challenged within 15 (fifteen) days of receipt.

8. Contract Withdrawal

8.1 The Seller reserves the right to withdraw from the contract without any penalty if there are facts or circumstances that alter the stability of the markets, the value of money, the conditions of the companies producing the raw material and the conditions of supply. The Seller will also have the right to withdraw from the contract without any penalty, should it become aware of the existence of protests, securities, as well as the start of court proceedings, bankruptcy proceedings, including out of court proceedings against the Buyer.

9. Confidentiality - Intellectual Property Rights

9.1 The Buyer may in no case disclose or transfer to third parties any confidential information, including commercial or other information owned by the Seller or under the control of the Seller, without the Seller's prior written consent.

9.2 All patents, copyrights, trademarks and/or any other intellectual property and/or confidential information regarding the Product shall remain the property of the Seller.

10. Applicable Law

10.1 These "General Terms and Conditions of Sale", as well as all sales contracts governed by them are governed by Italian law.

11. Court of Jurisdiction

11.1 Any dispute deriving from the interpretation, application, execution, termination of the contract of sale and/or of these "General Terms and Conditions of Sale" or in any case related to it, is subject to Italian jurisdiction and shall be exclusively under the jurisdiction of the Court of Como, also in the case of connection of lawsuits.

12. Data Processing

The Buyer states to have received the information note on the processing of personal data pursuant to article 13 of the Law Decree 196/2003

Sales Office

Via Stazione 25 – 22060 Carimate (CO)

Tel. +39 031 790625

Fax +39 031 791746

Manufacturing Plant

Via bosco II – 84091 Battipaglia (SA)

Tel. +39 0828 302235

Fax +39 0828 303921

www.alveco.info

info@alveco.info



POLYCARBONATE